

Mechanical Rotor Suspension without Compound-Stage

TURBOVAC 151, 151 C ClassicLine



Turbomolecular pumps without a purge gas facility are only suited for pumping of air or inert gases. They are not suited for pumping of aggressive or reactive gases.

TURBOVAC pumps with a "C" in the type designation are equipped with a purge gas facility.

The purge gas protects only the bearing area and the motor of the TURBOVAC.

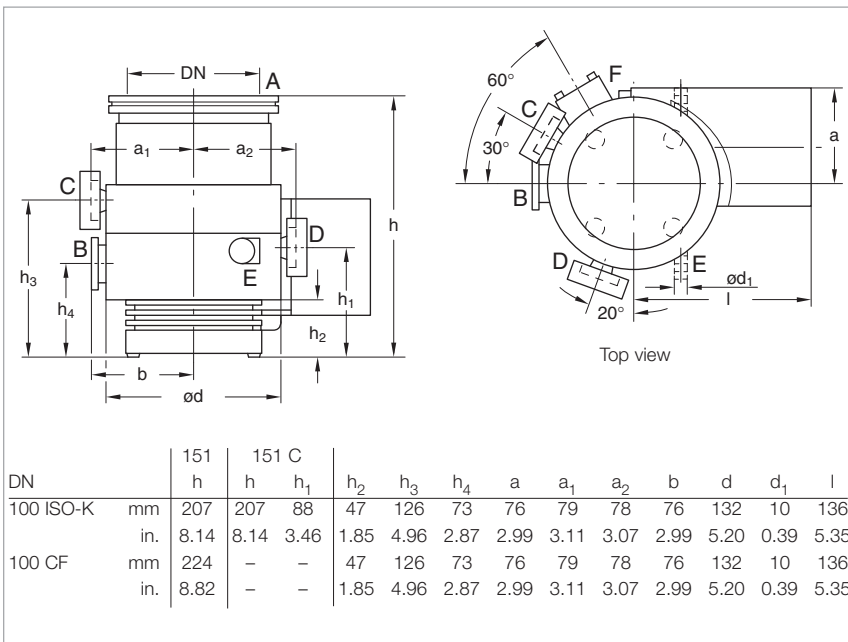

Dimensional drawing for the TURBOVAC 151 and 151 C

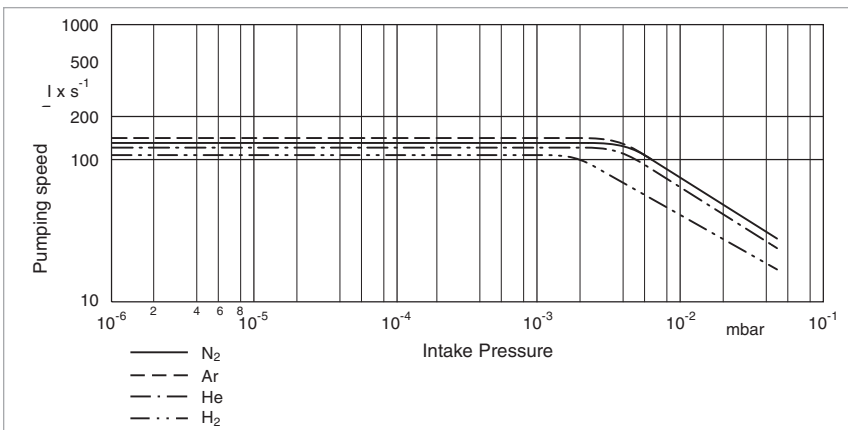

Pumping speed as a function of the inlet pressure (TURBOVAC 151 with flange DN 100)

Typical Applications

- Leak detectors
- Mass spectrometers
- Optical coating
- R & D
- UHV systems
- Particle accelerators
- Load locks and transfer chambers

Technical Features

- Small footprint
- Operation in any orientation
- Oil-free pump for generating clean high and ultrahigh vacuum conditions
- Bearing temperature measurement through the TURBO.DRIVE TD 20 classic

Advantages to the User

- Space-saving
- Easy to integrate into complex vacuum systems
- Low operating costs
- Highly reliable operation also in processes loaded with particles

Technical Data

TURBOVAC 151 (C)

Inlet flange	DN	100 ISO-K	100 CF
Pumping speed			
N ₂	l x s ⁻¹	145	145
Ar	l x s ⁻¹	150	150
He	l x s ⁻¹	135	135
H ₂	l x s ⁻¹	115	115
Max. gas throughput			
N ₂	mbar x l x s ⁻¹	1.5	1.5
Ar	mbar x l x s ⁻¹	1.3	1.3
H ₂	mbar x l x s ⁻¹	1.0	1.0
Compression ratio			
N ₂		1 x 10 ⁹	1 x 10 ⁹
He		2 x 10 ⁴	2 x 10 ⁴
H ₂		8 x 10 ²	8 x 10 ²
Ultimate pressure	mbar (Torr)	< 1 x 10 ⁻¹⁰ (< 0.75 x 10 ⁻¹⁰)	< 1 x 10 ⁻¹⁰ (< 0.75 x 10 ⁻¹⁰)
Max. continuous inlet pressure ¹⁾	mbar (Torr)	5 x 10 ⁻² (4 x 10 ⁻²)	5 x 10 ⁻² (4 x 10 ⁻²)
Max. foreline pressure for N ₂	mbar (Torr)	5 x 10 ⁻¹ (4 x 10 ⁻¹)	5 x 10 ⁻¹ (4 x 10 ⁻¹)
Recommended forevacuum pump		from TRIVAC D 4 B to D 16 B	from TRIVAC D 4 B to D 16 B
Run-up time at 95% of nominal speed	min	≈ 2	≈ 2
Purge / vent port	DN	10 KF	10 KF
Cooling water connection (hose nozzles)	mm (in.)	10 (0.39)	10 (0.39)
Weight, approx.	kg (lbs)	8 (17)	8 (17)
Max. power consumption / Ultimate pressure	VA	680	680
	VA	480	480

¹⁾ Water-cooled



Technical Data

TURBO.DRIVE TD 20 *classic*

Mains connection, 50 - 60 Hz; selectable	V	100 to 240 (-15 % / +10 %)
Max. output voltage	V	3 x 47
Overload current limit	A	5
Permissible ambient temperature	°C (°F)	0 to +45 (+32 to +113)
Protection class	IP	20
Dimensions (W x H x D)	mm (in.)	213 x 128 x 315 (1/2 19", 3 HU) 8.39 x 5.04 x 12.40 (1/2 19", 3 HU)
Weight, approx.	kg (lbs)	4 (8.8)

Ordering Information

TURBOVAC 151 (C)

TURBOVAC 151 (C) without Compound Stage	P	Part No.		
DN 100 ISO-K, water-cooled DN 100 ISO-K, water-cooled (C version) DN 100 CF, water-cooled DN 100 CF, water-cooled (C version)		856 31 856 35 856 32 103 41		
Mandatory Accessories		FC	PS	
TURBO.DRIVE TD 20 <i>classic</i> without interface with RS 232 C interface with RS 485 C interface with Profibus with 25 pol I/O		800075V0001 800075V0002 800075V0004 800075V0003 800075V0005		
Connecting cable TURBOVAC - frequency converter 3 m (10.5 ft) 5 m (17.5 ft) 10 m (35.0 ft) 20 m (70.0 ft) 50 m (175.0 ft) 60 m (210.0 ft) 80 m (280.0 ft) 140 m (490.0 ft)		857 65 857 66 857 67 857 68 800152V0008 800152V0007 800152V0080 800152V0140		
Mains cable 3 m (10.5 ft) EURO plug UK plug US plug 5-15 P (220 V AC) 2 m (7.5 ft) US plug 115 V AC		800102V0002 800102V0003 800102V1002 992 76 513		
Forevacuum pump TRIVAC D 4 B 1 phase motor; 230 V, 50 Hz		112 45		
TRIVAC D 8 B 1 phase motor; 230 V, 50 Hz		112 55		
TRIVAC D 16 B 1 phase motor; 230 V, 50 Hz 1 phase motor; 230 V, 50/60 Hz 3 phase motor; 230/400 V, 50 Hz / 250/440 V, 60 Hz		112 65 113 25 112 66		
SCROLLVAC SC 30 D 1 phase motor; 200-230 V, 50/60 Hz 1 phase motor; 100-115 V, 50/60 Hz 3 phase motor; 380-415 V, 50 Hz / 200-230 V, 460 V 60 Hz		133 002 133 102 133 004		
For further types, see our Full Line Catalog				

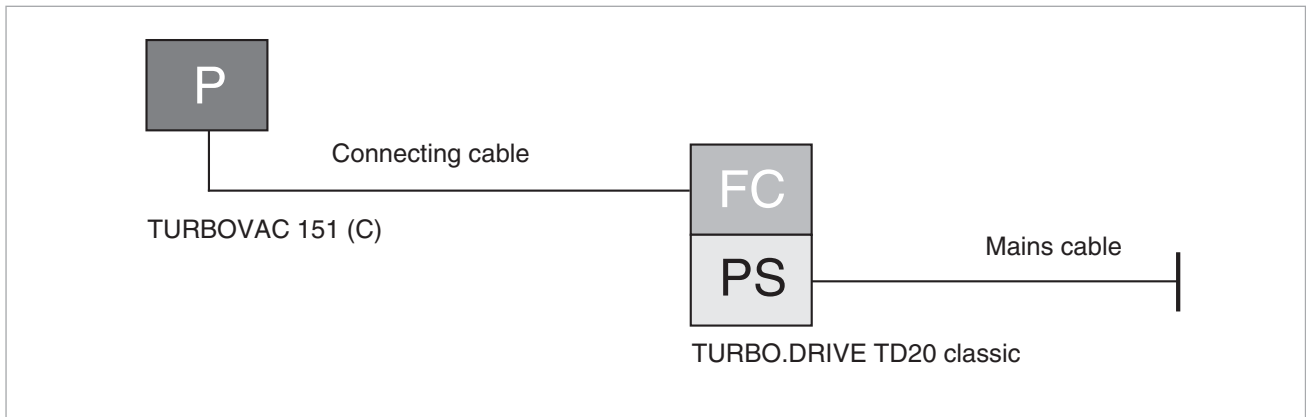

Ordering Information

TURBOVAC 151 (C)

Accessories, optional	Part No.
Air cooling unit 230 V AC 115 V AC 100 V AC	855 31 894 08 800152V0016
Flange heater DN 100 CF, 230 V, 50 Hz DN 100 CF, 115 V, 60 Hz	854 27 854 28
Vibration absorber DN 100 ISO-K DN 100 CF	800131V0100 500 071
Solenoid venting valve, with gas admission filter, normally closed 24 V DC, DN 16 KF	800120V0011
Power failure venting valve, with gas admission filter, normally open 24 V DC, DN 16 KF	800120V0021
Purge gas and venting valve Gas flow at 1 bar 0.4 mbar x l x s ⁻¹ (24 sccm), Pump connection DN 10 KF / gas connection G 1/4" 230 V AC 100 - 115 V AC 24 V DC	800152V0014 800152V0041 800152V0013
Gas filter to G 1/4-in. for purge gas and venting valve	800110V0012
Replacement filter (for gas filter to G 1/4-in. for purge gas and venting valve)	200 18 515
Included in the Delivery of the Pump	P
Inlet screen, centering ring with FPM sealing ring, outer ring	ISO-K
Inlet screen	CF
Centering ring with O-ring, clamping ring	Foreline Flange
Pivoted threaded fittings to replace the included hose nipples	Water Cooling