



ECODRY plus

Let's turn workplaces
into quieter spaces





So quiet, you'll hardly notice it

What makes a mountain stroll so refreshing? Taking in amazing sights, breathing crisp air – and soaking up the quiet. Hearing only the wind, perhaps a bird-call or two, your thoughts.

Focusing on the essentials.

Workplaces always entail a certain amount of noise. But creating a good working environment means ensuring health and well-being for those who spend time there, so that they can focus on achieving accurate results.

Facilities around the world can now become quieter, thanks to the new dry vacuum pump Ecodry plus. It does its job reliably, without drawing attention to itself. In fact, at 52 dB(A), Ecodry plus is the quietest in its class.

Why is quietness important?

At levels above 55 dB(A), sounds quickly become distracting and annoying. If these loud noises persist over long periods, you experience unease, irritability, increased blood pressure.

In a word: stress. A quieter environment, on the other hand, lets you “hear yourself think” and focus on the task at hand, making work more pleasant – and productive.

How does Leybold do it?

In terms of noise reduction, the Ecodry plus represents the summit of German engineering expertise. Non-contacting rotors with low vibration, a low-power drive unit, a low-noise fan for efficient cooling, and a cutting-edge silencer add up to an acoustic milestone.

Clean pumping has never been quieter.



65 dB(A)

Babbling brook



60 dB(A)

Summer shower



55 dB(A)

Conversation



52 dB(A)

**Quieter than a conversation
or an air conditioner**

German engineering excellence:
ECODRY plus uses innovative technologies to deliver superior performance.

**Half as loud as other pumps
in its class**

- Low-noise air cooling system
- Optimized silencer integrated in exhaust
- Non-contacting rotors with minimal vibration and noise
- Housing with integrated acoustic insulation

“Everyone who has seen the ECODRY plus pump in action, has been very impressed by its compact size, low noise level, and high quality.

The ECODRY plus is by far the quietest of any roughing pump we’ve ever used.”

Mass Spectrometer Scientist

Designed to serve your needs

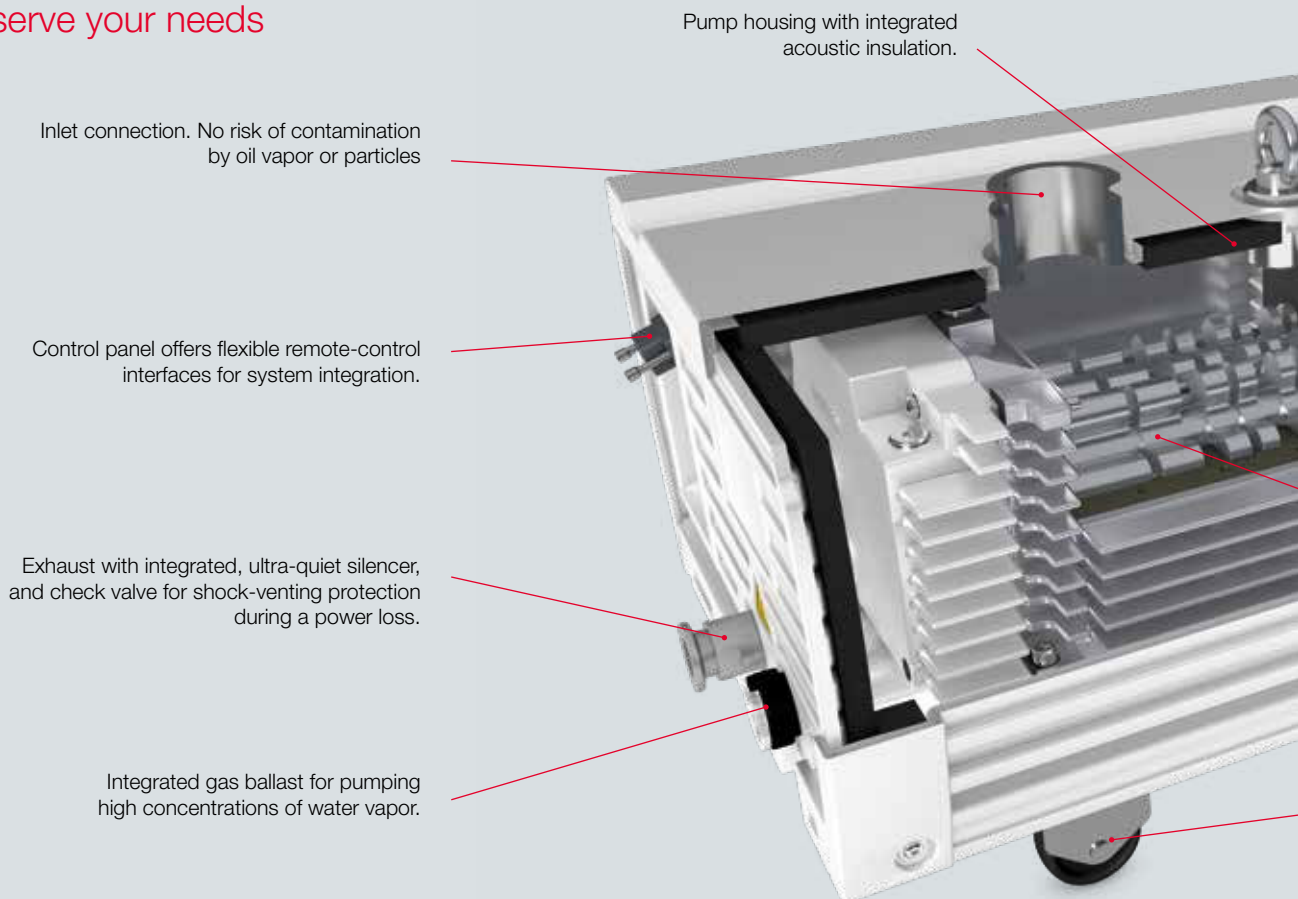

Quieter is just the beginning

Yes, the ECODRY plus is exceptionally quiet – but it's also incredibly clean. The multi-stage Roots design is a dry technology. No oil, particles, or dust are present in the pumping chamber. Clean vacuum is assured, smart features keep you flexible, and maintenance is reduced to a bare minimum.

Benefit from a clean pump

- No oil – Thanks to its dry design, no oil is present in the pump chamber.
- No particles – Contact-free pump design produces no wear particles.
- No contamination – Samples can be reliably analyzed and compared, time after time.
- No smells – Dry also means odor-free, so workplaces become more appealing.
- No change of oils or seals – The pump needs no auxiliary materials and no maintenance by the customer.

“A dry pumping technology, no wear, no particle generation – simply: it's a clean pump.”

Particle Accelerator Engineer

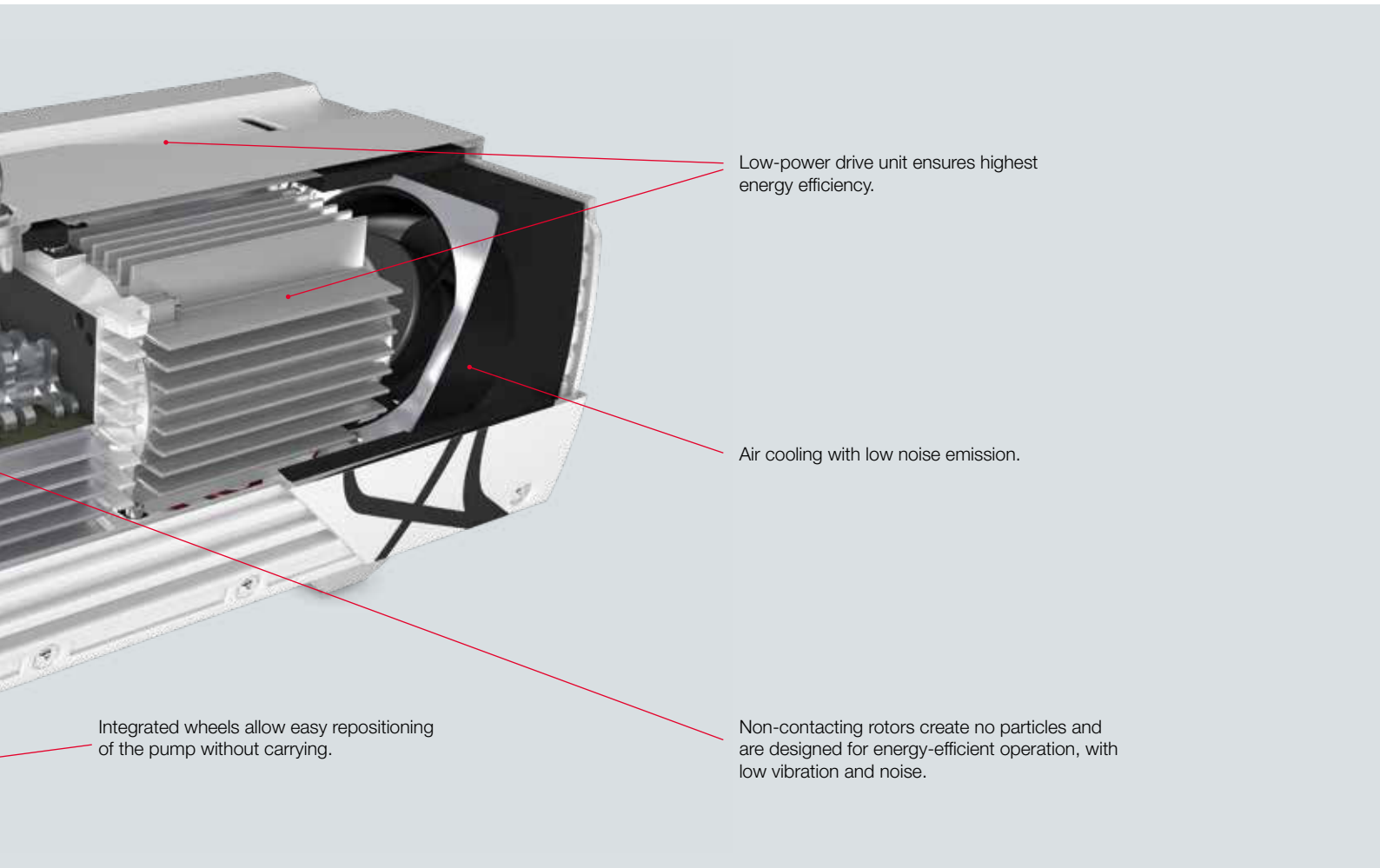

Low-power drive unit ensures highest energy efficiency.

Air cooling with low noise emission.

Integrated wheels allow easy repositioning of the pump without carrying.

Non-contacting rotors create no particles and are designed for energy-efficient operation, with low vibration and noise.

Achieve more with less

Requiring no maintenance by users, the ECODRY plus frees up considerable resources. Other ways in which “less” really means “more”:

- Low operating costs – and plenty of performance, with pumping speed optimized for analytical applications.
- Less power consumption – for more energy efficiency. Less heat generation results in lower air conditioning costs.
- Fewer limitations – with low EMC emission and low leakage current, the ECODRY plus can be powered via regular wall sockets.

- Compact size – The small footprint enables more flexibility where space is limited.

Power consumption at ultimate pressure

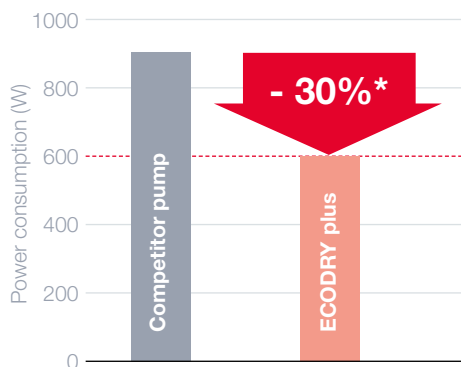

* > 30% reduction in power consumption. This adds up to annual savings of 500 dollars or more.

Create a smoother workflow

Easy handling makes working with the ECODRY plus even more pleasant:

- The integrated frequency converter ensures reliable pumping performance over a broad frequency and voltage range.
- Rolling on integrated wheels, the pump can simply be moved as needed.
- All connectors are located on one side, allowing for simplified installation.
- Stable performance during whole product life gives you peace of mind.

Compact and flexible



Flexible control modes:

- Manual operation with integrated switch.
- Remote controlled via digital I/O interface from customer system.
- Computer-controlled via RS485/MODBUS.

Performance should be seen, not heard

Designed to serve – quietly

In analytical instruments like **mass spectrometers**, the vacuum pump is an indispensable component that is expected to provide reliable vacuum without drawing too much attention to itself.

With the Ecodry plus acoustic enclosures for noise reduction are no longer required – an Ecodry plus emits half the noise of other pumps in its class. And thanks to its flexible interfaces, the pump can be remote-controlled by the instrument control system.

Minimal vibration for ultra-sharp microscopy

Electron microscopes need dependable vacuum pumps for backing multiple turbomolecular pumps. To achieve highest-resolution images, the pump must not transfer any noise or vibration to the instrument.

The Ecodry plus is not only the quietest pump in its class – it also creates minimal vibration due to its smooth rotation mechanism. This reduced noise and vibrations benefits resolution – and the lab's employees. Blurred images are a thing of the past!

Robust and reliable

In **cryo-pump regeneration**, the pump needs to handle high amounts of water vapor – and possibly solvents – and transport it out of the vacuum chamber.

The Ecodry plus boasts high water-vapor tolerance and is built for utmost reliability. Flexible system integration is easy, thanks to the available remote-control interfaces.

Pumping speed curves

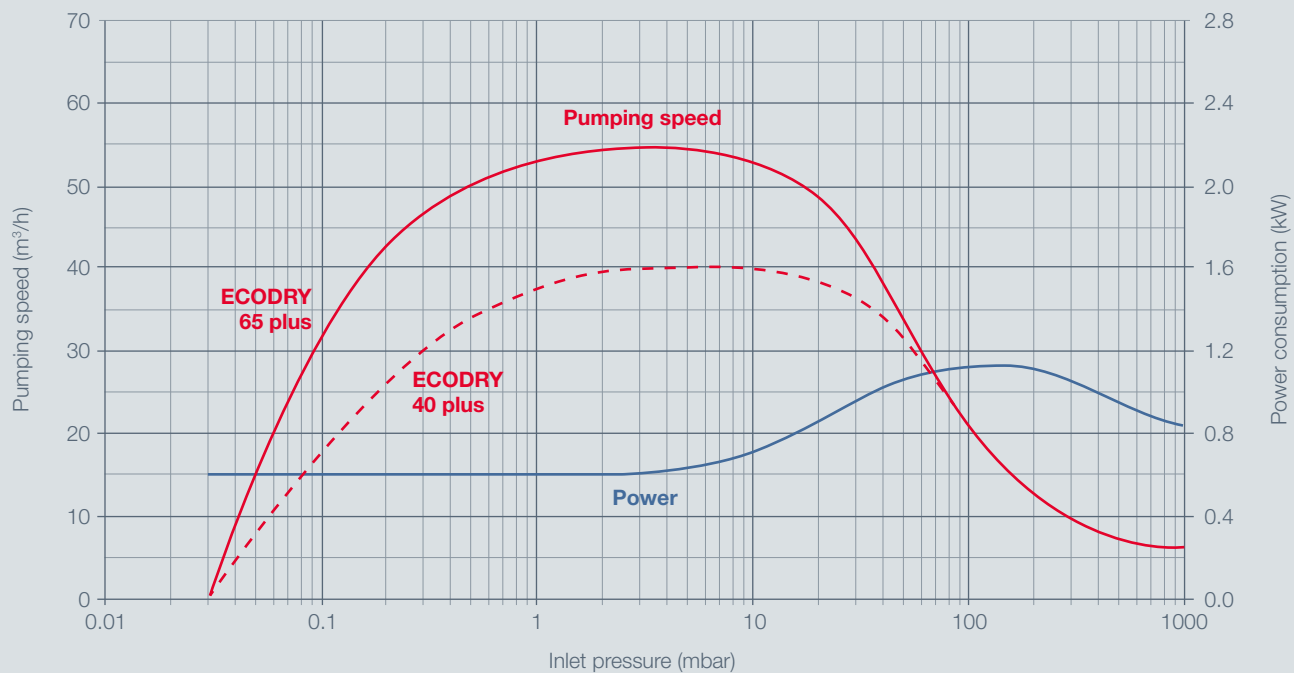

No contamination, extra-low maintenance

Ultra-high vacuum (UHV) applications require reliable backing pumps for supporting turbomolecular pumps. To avoid disturbing sensitive measurements, noise should be kept to an absolute minimum and contaminants prevented.

The ECODRY plus is extremely quiet and easy to operate – ideal for UHV labs. It offers sufficient pumping performance to back systems of several turbomolecular pumps. In addition, the clean pumping mechanism produces no contaminants. The ECODRY plus is maintenance-free for users – so scientists can concentrate on their experiments without needing to service the pump.

Clean, mobile, and strong

Large-scale accelerators have large-volume vacuum chambers to be evacuated. Contamination by dust or oil must be avoided at all times. In addition, pumps need to be able to handle continuous exposure to water vapor.

The ECODRY plus fulfills the high requirements for cleanliness and provides enough pumping speed to evacuate chambers of considerable volume. Due to its high water-vapor capacity, it operates reliably, even in the case of heavy desorption from chamber walls. What's more, the pump is lightweight and compact and can be easily moved around on wheels.

Technical data

Ordering information

ECODRY		40 plus	65 plus
Peak pumping speed	m ³ /h	40	55
Ultimate pressure	mbar	< 3 x 10 ⁻²	< 3 x 10 ⁻²
Water vapor capacity	g/h	300	500
Cooling		Air	Air
Power consumption at ultimate pressure	W	600	600
Mains connector		IEC EN60320 C20	IEC EN60320 C20
Noise level	dB(A)	< 52	< 52
Protection class		IP42	IP42
Operating temperature	°C	+5 to +40	+5 to +40
Inlet flange		DN 25 ISO-KF	DN 40 ISO-KF
Exhaust flange		DN 16 ISO-KF	DN 16 ISO-KF
Weight	kg	43	43
Dimensions W x L x H	mm	320 x 623 x 298	320 x 623 x 298
Certifications		CE, NRTL (cTUVus), RoHS	

ECODRY	Part no.	40 plus	65 plus
Vacuum Pumps			
High voltage: 200-240 V (+/- 10%), 50/60 Hz		161 040 V01	161 065 V01
Low voltage: 120 V (+/- 10%), 50/60 Hz		161 040 V21	161 065 V21
Inlet screens			
DN 40 ISO-KF			E41 170 121
DN 25 ISO-KF		E41 170 206	
Mains cables (mandatory accessories)			
EU (CEE 7/7 - C19, 2.0 m)			161 810 EU
UK (BS 1363 - C19, 2.0 m)			161 810 UK
US 120 V only (NEMA 5-15P - C19, 2.0 m)			141 103 US
US 200-240 V only (NEMA 6-15P - C19, 2.5 m)			161 810 US
Other accessories			
Casing assembly mounting kit			161 831 A
RS485/USB connecting cable for X104 interface, 1.8 m			161 820 USB
Gas ballast blank plug			161 832 A
Purge gas adapter (10 mm quick connect)			161 833 A
LEYASSIST software			230 439 V01



Leybold GmbH
Bonner Str. 498 · 50968 Köln

T +49 (0) 221-347-0
F +49 (0) 221-347-1250
info@leybold.com
www.leybold.com
www.ecodry-plus.com

