

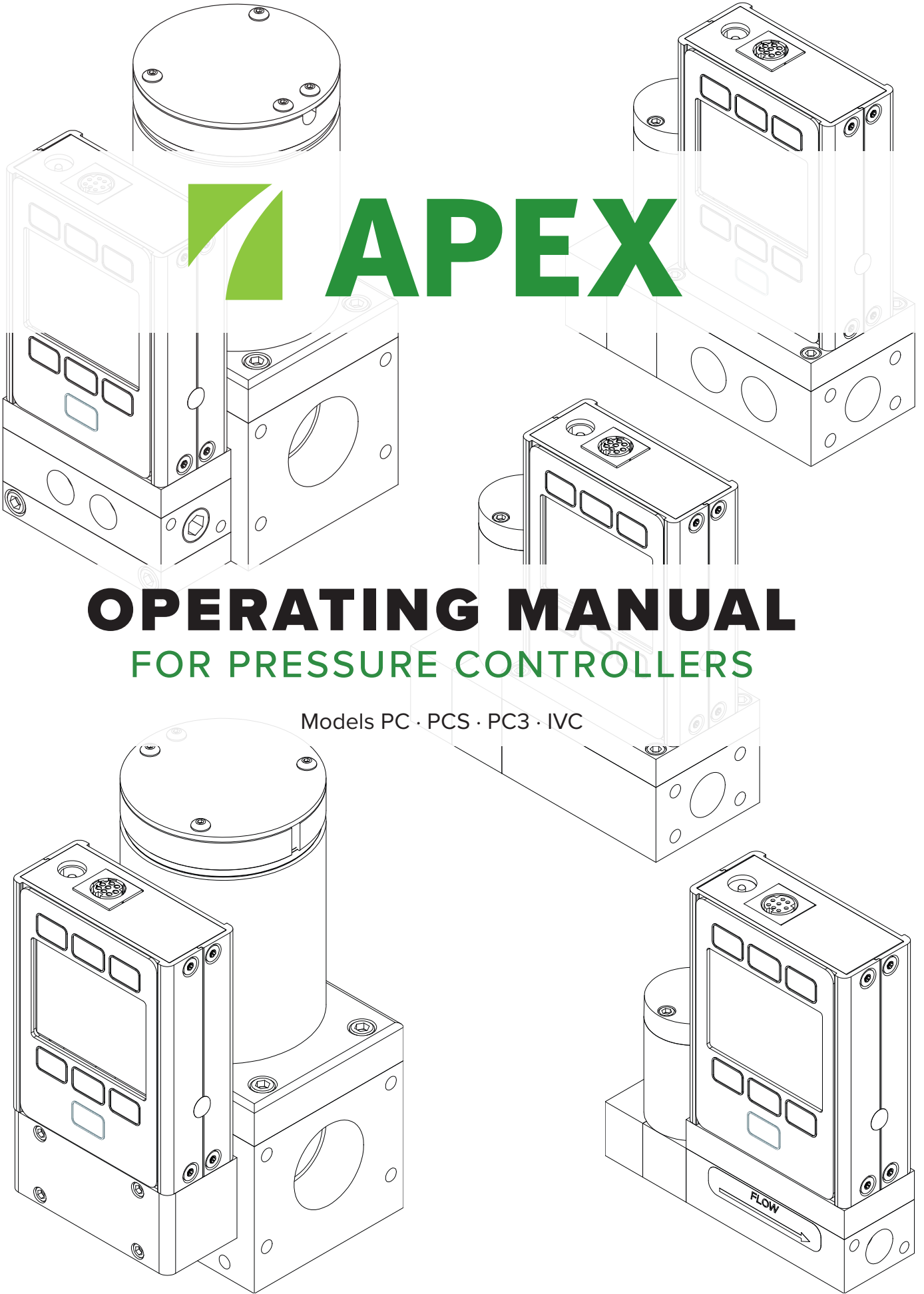

OPERATING MANUAL

FOR PRESSURE CONTROLLERS

Models PC · PCS · PC3 · IVC



Introduction

Your pressure controller has many innovative features:

- **1000 readings per second** guarantees high resolution data, [page 11](#).
- **Backlit display with adjustable contrast** is easy to read even in direct sunlight. In dimly lit areas, press the bottom button to turn on the backlight, [page 19](#).
- **Ability to control gases and liquids** to accommodate a wide range of pressure control applications.
- **Connection to a computer for control and data logging** to capture all pressure data for logging and analysis, [page 20](#).

This manual covers the following instruments:

- Absolute, gauge, and differential pressure controllers
- Anti-corrosive absolute, gauge, and differential pressure controllers
- Remote-sensing pressure controllers
- Integrated vacuum controllers
- external sensor pressure controllers

For support or questions regarding the use or operation of this device, please contact support using the information on [page 16](#).

Serial #: _____

Next Calibration: _____

NIST This device comes with a NIST-traceable calibration certificate.



This device conforms to the European Union's Restriction of Use of Hazardous Substances in Electrical and Electronic Equipment (RoHS) Directive 2011/65/EU.



This device complies with the requirements of the Low Voltage Directive 2014/35/EU and the EMC Directive 2014/30/EU and carries the CE Marking accordingly.



This device complies with the requirements of the European Union's Waste Electrical & Electronic Equipment (WEEE) Directive 2002/96/EC

DOC-MANUAL-PC-G Rev 0 • 2021.08.19

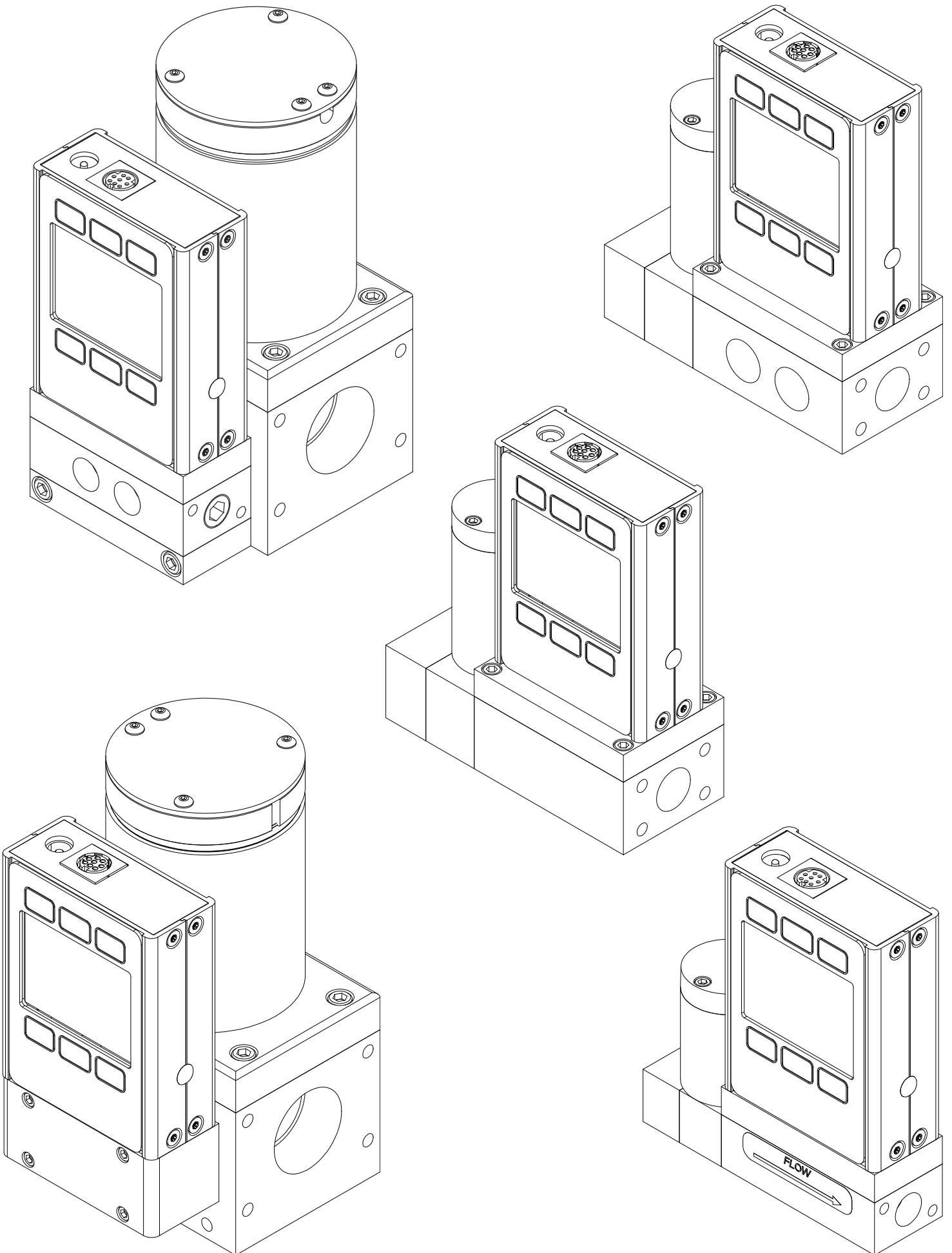

Contents

Introduction	3	Serial Communication	20
Quick Start Guide	5	Modbus RTU Communication	20
Getting Started	6	Establishing Communication	20
Getting to Know Your Pressure Controller	6	Communication Programs	20
The Pressure Controller Display.....	6	Configuring PuTTY.....	20
Status Messages.....	6	Polling Mode.....	20
Mounting	6	Streaming Mode.....	21
Filters	6	Taring	21
Device Ports	7	Collecting Data	21
Connecting Your Pressure Controller	7	Commanding a New Setpoint	22
Forward (Downstream) Pressure Control.....	8	Sending Setpoints as Floating Point Numbers.....	22
Back Pressure Control.....	8	Quick Command Guide	22
Differential Pressure Control.....	8	Troubleshooting	23
Remote-Sensing Controller.....	9	General Use	23
Integrated Vacuum Controllers (IVC).....	9	Pressure Readings	23
Using Pressure Instruments with Liquids.....	9	Serial Communications	24
Power and Signal Connections	10	Maintenance	24
Analog Signals.....	10	Cleaning	24
Displaying Live Data	11	Recalibration	24
Main Display	11	Reference Information	25
Taring Your Pressure Controller	11	Engineering Units	25
Option: Color TFT Display	11	Pinouts	26
Control	12	8-Pin Mini-DIN (Default).....	26
Changing the Setpoint	12	Locking Industrial Connector Pinout.....	26
Adjusting Setpoint with an IPC.....	12	9-Pin D-Sub Connector Pinouts.....	27
Setpoint Setup	12	15-Pin D-Sub Connector Pinouts.....	27
Using Autotare.....	12	M12 Connector Pinouts.....	28
Changing Between Setpoint Sources.....	12		
Managing Setpoint with an Idle Modbus Connection.....	12		
Managing Setpoint on Power-Up.....	12		
Establishing Setpoint Limits.....	13		
Control Loop	13		
Changing the Controlled Variable.....	13		
Adjusting the PD/PDF or PD ² I Control Algorithms.....	13		
Tuning the PD ² I Control Algorithm.....	14		
Troubleshooting Valve Performance with PID Tuning.....	14		
Using a Control Deadband for Pressure Control.....	14		
Setpoint Ramping	15		
Setting the Ramp Rate.....	15		
Ramping Options.....	15		
Displaying Valve Drive Percentage	15		
Device Information	16		
Setup	17		
Sensor Setup	17		
Choosing Engineering Units.....	17		
Pressure Averaging.....	17		
Zero Band.....	17		
Configuring Serial Communications	18		
Unit ID.....	18		
Modbus RTU Configuration.....	18		
Baud Rate.....	18		
Display Setup	19		
Main Screen Options.....	19		
Screen Lighting.....	19		
Display Rotation.....	19		
Advanced Setup	19		

Quick Start Guide

Setup

- **Connect your pressure controller.** Ensure that flow will pass through your device in the same direction as the arrow on the flow body (usually left to right).
- **Choose your engineering units.** You can choose the measurement units by selecting **MAIN MENU** → **SETUP** → **Sensor** → **Engineering Units** (page 17).

Operation: Pressure Verification

Monitor live pressure readings. Readings are updated and displayed on your device in real time (page 11).

Connectors and Buttons

The drawing to the right represents a typical configuration of a standard pressure controller. **Your pressure controller's appearance and connections may differ** (page 16).

Backlight

The monochrome display comes equipped with a backlight. **To toggle the backlight power, press the bottom button on the front of your device.**

For optional color TFT displays, pressing this button will turn off the display to conserve power. See page 11.

Maintenance and Care

- Pressure controllers do not require cleaning when flowing clean, dry gases (page 24).
- Calibrate your device annually. To schedule a calibration, please contact support (page 16).

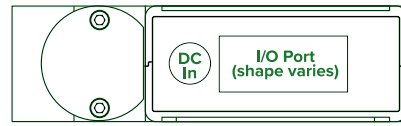

This is a typical gauge pressure configuration.

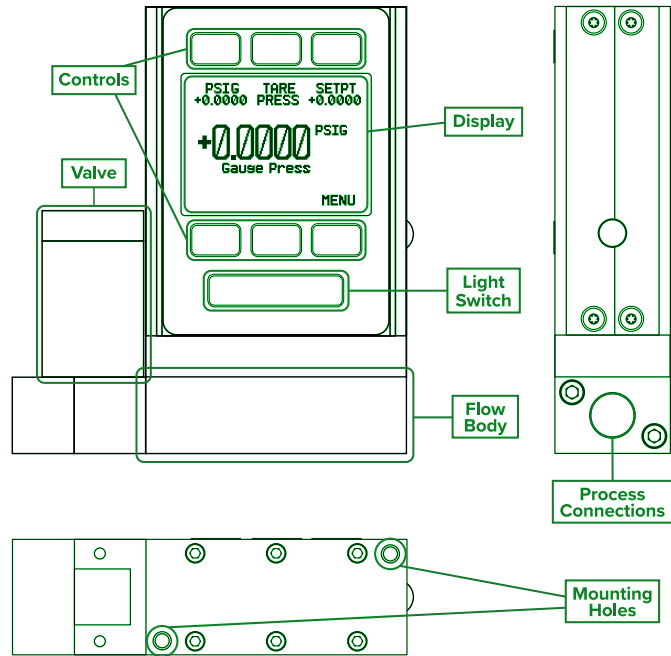

This is a typical differential pressure configuration.

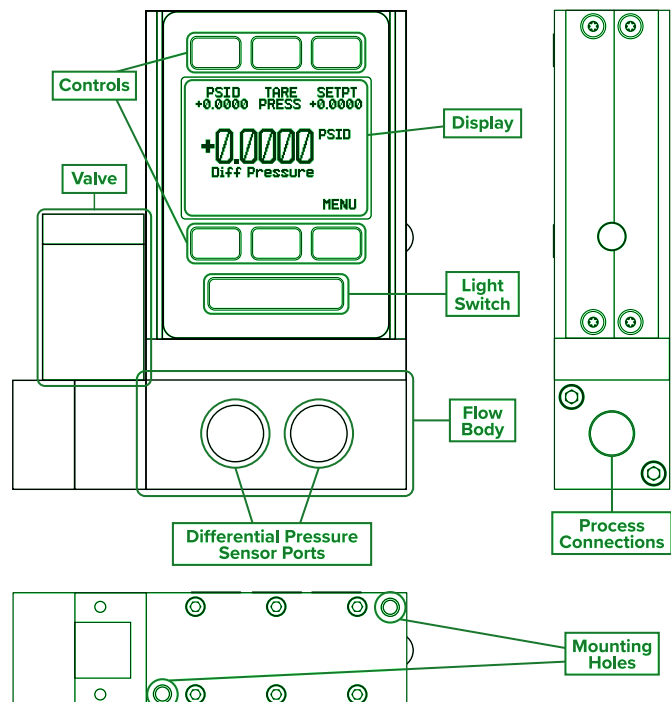

Getting Started

Getting to Know Your Pressure Controller

The Pressure Controller Display

The figure below identifies the various features of the main pressure controller display.

- 1 Highlights **pressure** in the center of the display.
- 2 **Tares the pressure** (typically unavailable for absolute pressure devices) ([page 11](#)).
- 3 Opens a menu to set the **pressure control setpoint** ([page 12](#)).
- 6 Enters the **main menu** system ([page 11](#)).
- 7 **Toggles the backlight** (more display options are on [page 19](#)).



Note: Buttons 4 and 5 have no functions on the main display for pressure devices.

Status Messages

Status messages are shown to the right of the main readout number. In the example to the right the **LCK** message indicates that the front display is locked.

- ADC** Analog-digital converter error
- LCK** Front display is locked
- POV** Pressure over range of device

Mounting

Pressure controllers do not require straight runs of pipe upstream or downstream. Most pressure controllers can be mounted in any position, including upside-down. Corrosive-resistant pressure controllers use media-isolated sensors that must be tared after changing their orientation.



Caution: Pressure controllers that use large Rolamite valves (PCR, PCR3, PCRS) should be mounted with their valve oriented vertically (right-side up). Please contact support for other orientations.

Filters

When pressure drop is not a concern, use in-line sintered filters to prevent large particulates from entering the pressure controller. Suggested maximum particulate sizes are as follows:

- **20 microns** for PC, PCP, PCH, PC3
- **40 microns** for PCR, PCR3

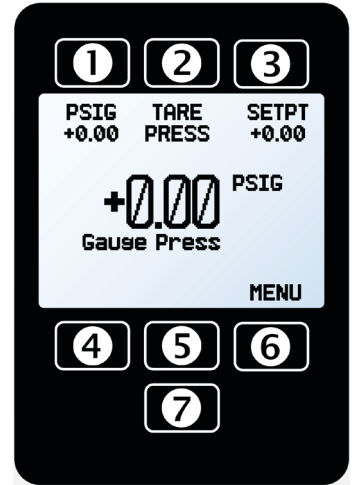

The **main display**. Note bottom button (7), which toggles the device backlight.

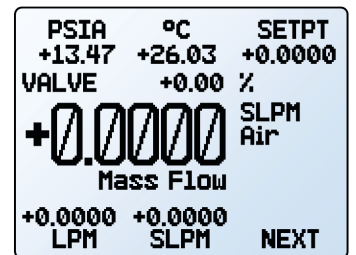

The **main menu** with valve position information, and a **LCK** status.

Device Ports

Your pressure controller has been shipped with plastic plugs fitted into its ports. To decrease the chance of contaminating the flow stream, do not remove these plugs until you are ready to install the device.

Standard pressure controllers have female inlet and outlet ports. VCR® and other specialty fittings may have male connections.

- If you are using a fitting that does not have a face seal, use thread-sealing Teflon tape to prevent leakage around the port threads, but **do not wrap the first two threads**. This will minimize the possibility of getting tape into the flow stream.
- Face seal fittings do not need Teflon tape applied to the threads.



Warning: *It is not recommended to use pipe dopes or sealants on the process connections as these compounds can cause permanent damage to the controller should they get into the flow stream.*

Connecting Your Pressure Controller

Connect the controller so that the flow travels in the same direction as the flow arrow, usually from left to right from the front of the device



Warning: *Using the pressure controller above the maximum specified common mode or burst pressure will result in permanent damage to the internal pressure sensors.*

Range	Burst Pressure	Maximum Allowed Common Mode Pressure (Differential Pressure Only)
0.07-100 PSI	3x full scale	200 PSIG (750 PSIG for anti-corrosive models)
500 PSI	1.5x full scale	750 PSIG
1000-3000 PSI	1.5x full scale	N/A

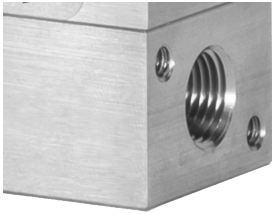

A default NPT female connection.

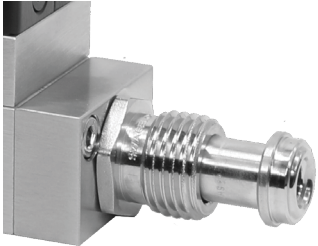

A male VCR®-compatible connection.

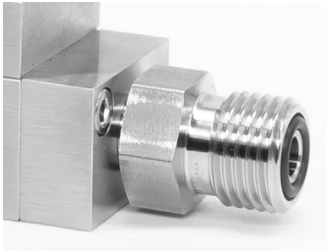

A male VCO®-compatible connection.

Applications

Forward (Downstream) Pressure Control

When the valve is located on the upstream side (direct control), the sensor will control pressure downstream. This configuration follows our standard pressure control algorithm. Note: the valve opens to increase pressure, and closes to decrease pressure.

Example:

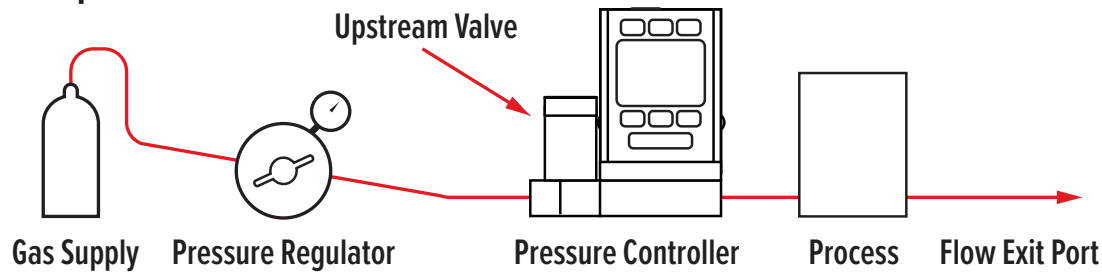

Back Pressure Control

When the valve is located on the downstream side (inverse control), the sensor will control pressure upstream. This configuration is referred to as a back pressure controller. This configuration follows our inverse pressure control algorithm. Note: the valve closes to increase pressure, and opens to decrease pressure.

Example:

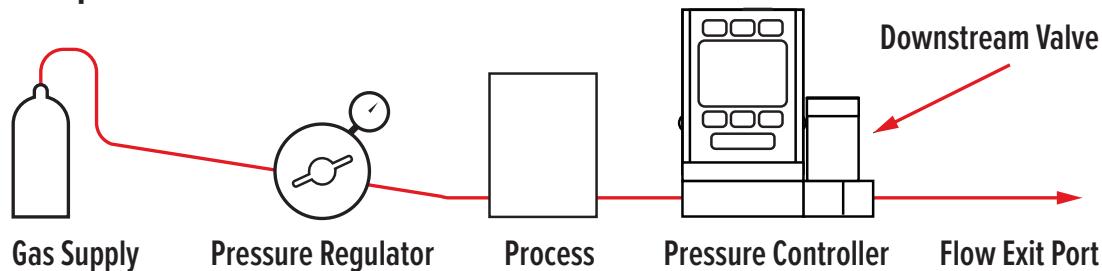

Note: Back pressure controllers include “DS,” for downstream valve, in their part codes.

Changing the Valve Orientation

The valve position on your pressure controller can be switched in the field. The controller must also be configured for either forward pressure control (direct control) or back pressure control (inverse control). If you need to switch from forward to back pressure control, contact support ([page 16](#)).

Differential Pressure Control

Differential pressure controllers have two ports for connecting to the points in the system where the differential pressure is to be measured. The upstream port is for the higher pressure, and the downstream port is for the lower pressure. In these devices, the differential pressure ports have no flow, and are not connected to the flow path.

Remote-Sensing Controller

PC3-Series models sense and control the pressure at some point in the system outside of the pressure controller itself. All PC-Series controllers can be ordered with an additional NPT port on the front, which is connected directly to the pressure sensor in the device. The pressure sensor is isolated from the flow path in this configuration.

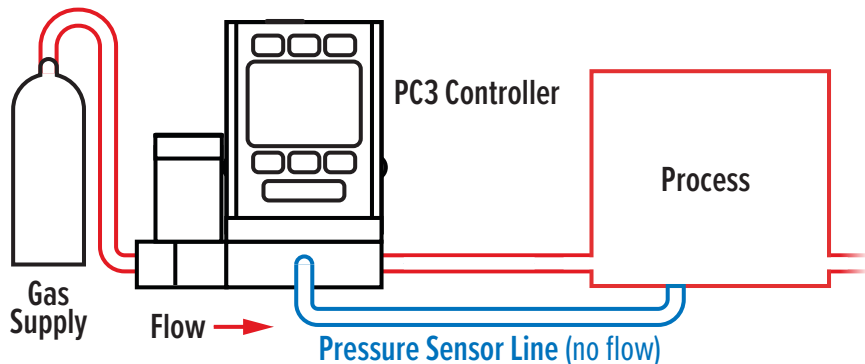

Integrated Vacuum Controllers (IVC)

IVCs are similar to the PC-Series absolute pressure controllers in functionality and in the navigation menus available on the screen. IVC devices are used in applications where precise control of vacuum is required, and are available with 10 TorrA, 100 TorrA, 1000 TorrA, and combined 1000 & 10 Torr sensors.

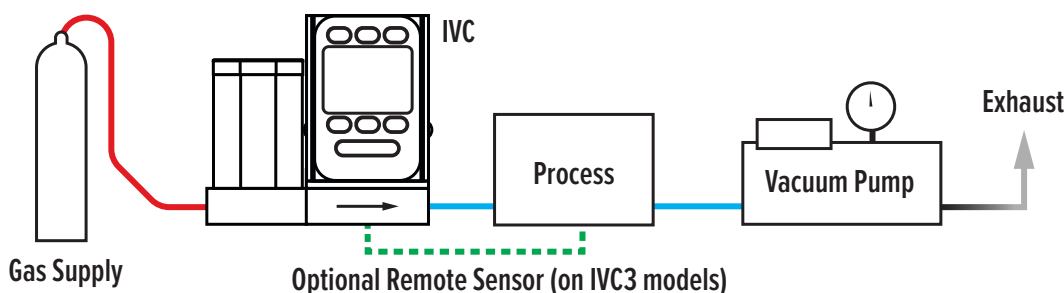

Integration of the vacuum sensor, control valve, and PID algorithm in a single device eliminates the need for an external vacuum sensor and throttle valve in your system. These devices have $\frac{7}{16}$ "-20 SAE ports, or optional VCR[®]-compatible, compression, and VCO[®]-compatible fittings. Process port sizes may change depending on the valve on your device.

Using Pressure Instruments with Liquids

Many pressure devices may be used with chemically-compatible liquids, but a few warnings must be taken into account:

- Water is more than 55 times more viscous than air. This is important when sizing a pressure controller, as this significant increase in viscosity requires a larger valve to reach expected flow rates. For example, a PC-Series pressure controller sized to flow up to 20 SLPM of air will be limited to roughly 0.5 LPM of water (or similar fluid).
- The factory PID tuning is done using air. It may be necessary to adjust the PID tuning parameters when using a controller with liquid. Find more information, contact support ([page 16](#)) to help you through this tuning process.



Caution: Please check with customer support before using your pressure controller with liquids unless specifically ordered for this purpose.

Power and Signal Connections

Power can be supplied to your controller through either the power jack or the multi-pin connector on top of your device.



Note: Power requirements vary based on analog configuration and valve type. Please reference the associated specification sheet for power requirements.

Standard 8-Pin Mini-DIN Pinout

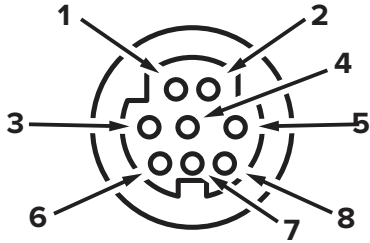

Female Connector: Device

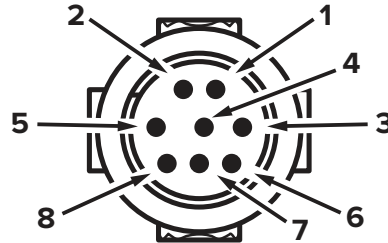

Male Connector: Cable



A pressure controller with the standard 8-pin Mini-DIN serial connector.

Pin	Function
1	Not Connected <i>Optional: 4–20 mA primary output signal</i>
2	Static 5.12 Vdc by default. <i>Optional: secondary analog output (4–20 mA, 0–5 Vdc, 1–5 Vdc, 0–10 Vdc) or basic alarm</i>
3	Serial RS-232 RX / RS-485(-) Input Signal (receive)
4	Analog Setpoint Input
5	Serial RS-232 TX / RS-485(+) Output Signal (send)
6	0–5 Vdc <i>Optional: 1–5 Vdc or 0–10 Vdc output signal</i>
7	Power In (as described above)
8	Ground (common for power, digital communications, analog signals and alarms)

The above pinout is applicable to all devices with the Mini-DIN connector. The availability of different output signals depends on the options ordered. Optional configurations are noted on the unit's calibration sheet.



Caution: Do not connect power to pins 1 through 6, as permanent damage can occur. It is common to mistake pin 2 (5.12 Vdc Output) as the standard 0–5 Vdc analog output signal. Pin 1 is normally a constant 5.12 Vdc.

More pinout configuration options begin on [page 26](#).

Analog Signals

Primary Analog Output Signal

Most devices include a primary analog output signal, which is linear over its entire range. For ranges that start at 0 Vdc, a zero-pressure condition is indicated at approximately 0.010 Vdc. Full scale pressure is indicated by the top of the range: 5 Vdc for 0–5 Vdc, 20 mA for 4–20 mA signals, and so on.

Option: Secondary Analog Output Signal

The default 8-pin Mini-DIN connector places the secondary analog output on pin 2 for both voltage and current signals. As pressure is the only measured parameter in the pressure series, this secondary analog output can be used as a comparison to the primary analog output.

Option: 4–20 mA Current Output Signal

Controllers with a primary or secondary output signal of 4–20 mA current require 15–30 Vdc power.



Caution: Do not connect 4–20 mA devices to “loop powered” systems, as this will damage portions of the circuitry beyond repair and void the warranty. If you must interface with existing loop powered systems, always use a signal isolator and a separate power supply.

Displaying Live Data

Main Display

The main display has four primary functions:

- Displaying live pressure data
- Setting the pressure controller's setpoint
- Taring the pressure ([page 11](#))
- Accessing the **main menu (MENU)**

Live data is measured 1000 times per second, and the LCD display is updated 10 times per second. The button next to the measurement highlights its value in the center.

Taring Your Pressure Controller

MENU → **TARE PRESS** or **TARES**

Taring ensures your pressure controller ensures its most accurate measurements. This function gives the pressure controller a zero reference for pressure measurements.

How to Tare

MENU → **TARES** → **TARE PRESS**

- Tares should be performed with the pressure controller open to atmosphere with no flow.
- Absolute pressure devices can be tared if purchased with the optional internal barometer, and then opened to atmosphere with no flow.
- Differential pressure devices require zero differential pressure between the P1 and P2 ports. They must be either open to atmosphere on both ports, or connected to the same pressure source.

When to Tare

- Before every new pressure measurement cycle
- After significant changes in temperature or pressure
- After dropping or bumping the pressure controller
- After installing the controller in a different orientation

Option: Color TFT Display

Instruments ordered with a color display are functionally the same as standard backlit monochrome instruments. The color enables additional on-screen information.

Multi-Color Display Indicators

- **GREEN:** Parameter labels and adjustments associated with the button directly above or below the label are presented in green.
- **WHITE:** The color of each parameter will be displayed in white when the device is operating within device specifications.
- **RED:** The color of a parameter will be displayed in red when its value exceeds 128% of the device's specifications.
- **YELLOW:** Menu items that are ready to be selected appear in yellow. This color replaces the > symbol in selections on monochrome display.



Note: Press the bottom button to turn off the color display backlight. The pressure controller remains in operation while the backlight is off.



Note: Color displays will require an additional 40 mA when using a 12 Vdc power supply. All other device specifications from your device's specification sheet remain in effect.

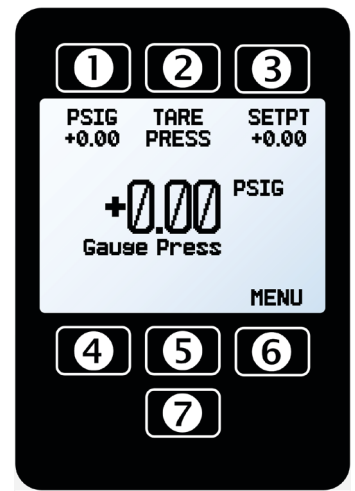

The **main display**. Note the bottom button (7), which toggles the device backlight.



Tare pressure by selecting **TARE PRESS** from the **main menu**.

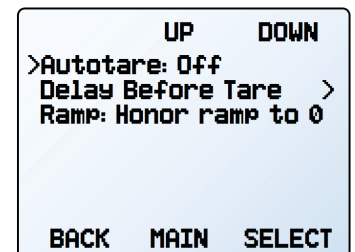

The **zero setpoint (autotare) menu** with Autotare on ([page 13](#)).



A pressure controller with an optional TFT screen.

Control

Changing the Setpoint

SETPT or MENU → CONTROL → Setpt:

The setpoint selection screen indicates the engineering units and maximum allowable setpoint (e.g., **PSIG: +10.000 Max**). To cancel a setpoint, press **CLEAR**, then **SET**.

Adjusting Setpoint with an IPC

For controllers ordered with a potentiometer control knob (IPC), the setpoint source must be set to analog for the controller to receive setpoint commands from the IPC (see “Changing Between Setpoint Sources” below).

Leave the IPC knob at the midpoint when it is not in use.

Setpoint Setup

Using Autotare

CONTROL → Setpoint Setup → Zero Setpoint

When the setpoint is zero, the controller will automatically tare itself if autotare is enabled. This menu also specifies how many seconds after a zero setpoint the controller will wait, under **Delay Before Tare**.



Caution: Auto-tare is typically not recommended for pressure control applications.

Setpoint ramping ([page 15](#)) can either be set to honor the ramp rate limit or go to zero as quickly as possible.

Changing Between Setpoint Sources

CONTROL → Setpoint Setup → Setpoint Source

Pressure controllers with RS-232 or RS-485 communication will accept setpoints from the front panel and serial commands ([page 20](#)), or from an analog signal.

- When the source is set to **Serial/Front Panel**, the controller will accept input from either the front panel, or an RS-232/RS-485 connection. Neither source is a slave of the other, so the controller will accept the most recent command from either source.
- When the source is set to **Analog**, the device ignores serial setpoint commands and will prevent setpoint input from the front panel.

Managing Setpoint with an Idle Modbus Connection

CONTROL → Setpoint Setup → On Modbus Timeout

If a Modbus connection is idle for a specified amount of time, the device can be configured to set a zero setpoint, or maintain the previous setpoint. The idle time will be infinite by default and can be adjusted ([page 18](#)).

Managing Setpoint on Power-Up

Power-Up Setpoint Value

CONTROL → Setpoint Setup → Power Up Setpoint → Value

By default, the controller remembers its last setpoint across power cycles. However, it can be changed to give a specified setpoint upon power-up by selecting **Fixed Setpoint** and entering in a value. If the setpoint will be digitally provided more often than every few minutes, use a fixed setpoint on power-up to avoid wearing out the device’s non-volatile memory.

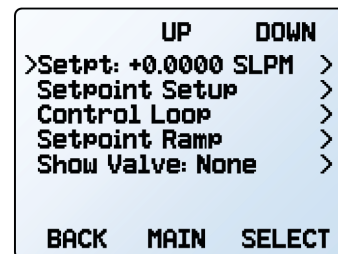

The control menu.



An IPC knob atop a controller.

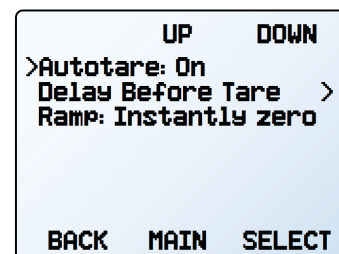

The zero setpoint (autotare) menu with autotare on.

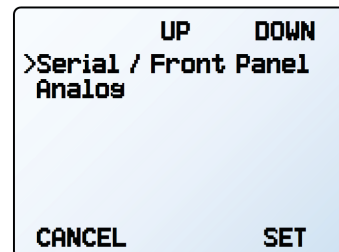

The setpoint source menu.

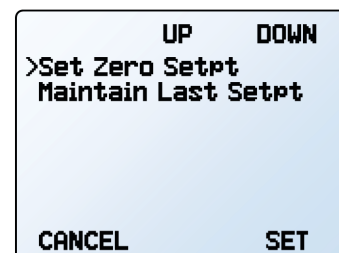

The modbus idle time menu.

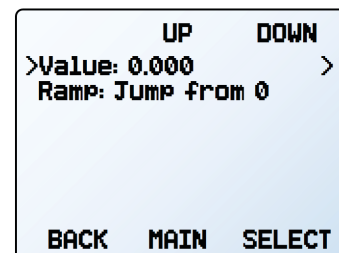

The power-up setpoint menu.

Power-Up Setpoint with Ramping

CONTROL → Setpoint Setup → Power Up Setpoint → Ramp

Any setpoint ramp will always start from zero on power-up. Similar to the zero setpoint option (page 12), the device can either honor the ramp rate (**Honor from 0**) or jump to setpoint (**Jump from 0**) as quickly as possible.

Establishing Setpoint Limits

CONTROL → Setpoint Setup → Setpoint Limits

The **setpoint limits** menu configures upper and lower limits for selecting a pressure control setpoint. By default, the controller will only be limited by its measuring range; however, more strict limits may be beneficial in certain critical applications.

Over a serial connection, requesting a setpoint outside the limit will be rejected and an error will be returned. When using an analog setpoint signal, setpoints that are outside of the setpoint limits are treated as if they were at the nearest limit. For example, if you request a setpoint that is below the lower limit, the controller sets the setpoint at the lower limit.



Note: When changing from one control loop variable to another, the pressure controller remembers setpoint limits as percentages of full scale. For example, a 15-PSIG limit on a 30-PSIG pressure controller (50% of full scale) will become a limit of 50% if the control loop is changed to valve drive.

Control Loop

Changing the Controlled Variable

CONTROL → Control Loop → Control

Selectable control loop variables include pressure (absolute, gauge, or differential) and valve drive.



Note: Pressure controllers with upstream valves will control the outlet pressure. Those with downstream valves can control upstream backpressure, but these must be configured for this type of control.



Warning: When changing the control loop, you may need to adjust the PID settings for optimal stability and speed of response.

Adjusting the PD/PDF or PD²I Control Algorithms

CONTROL → Control Loop → Loop Type

Your pressure controller uses an electronic closed loop controller to determine how to actuate its valve(s) in order to achieve the commanded setpoint. These settings were tuned for your specific operating conditions, but changes to your process sometimes require on-site adjustments to maintain optimal control performance. Fine-tuning your closed loop control may help issues with control stability, oscillation, or speed of response.

For most applications, the PD/PDF algorithm is recommended.

Tuning the PD/PDF Control Algorithm

The controller's default control algorithm (PD) employs pseudo-derivative feedback (PDF) control, which uses two editable variables:

- The larger the **D** gain, the slower the controller will correct errors between the commanded setpoint and the measured process value. This is equivalent to the **P** variable in common PDF controllers.
- The larger the **P** gain, the faster the controller will correct for offsets based on the size of the errors and the amount of time they have occurred. This is equivalent to the **I** variable in common PDF controllers.



Note: The **D** and **P** variables in the PD/PDF control algorithm are more typically referred to as **P** and **I**, respectively, in PDF controllers.

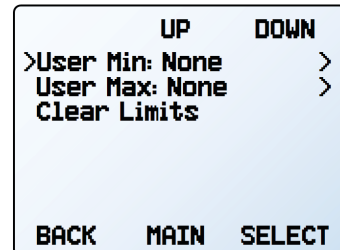

The setpoint limits menu.

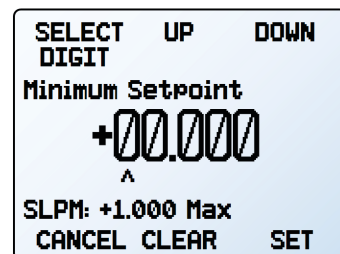

Setting a minimum setpoint.

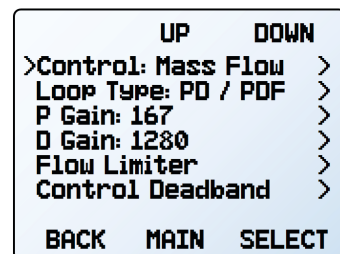

The control loop menu in PD/PDF control mode.

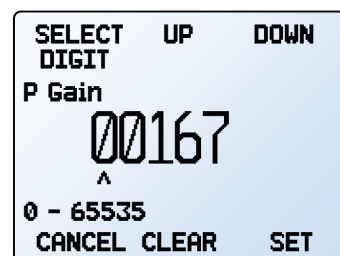

Setting a P Gain.

Tuning the PD²I Control Algorithm

The controller's PD²I control algorithm (also called PDDI) is used to provide faster response, most commonly in dual-valve flow and pressure controllers. This algorithm uses typical PI terms and adds a squared derivative term (**D**):

- The larger the **P** gain, the more aggressively the controller will correct errors between the commanded setpoint and the measured process value.
- The larger the **I** gain, the faster the controller will correct for offsets based on the size of the errors and the amount of time they have occurred.
- The larger the **D** gain, the faster the controller will predict future corrections based on the current rate of change in the system. This often results in slowing the system down to minimize overshoot and oscillations.

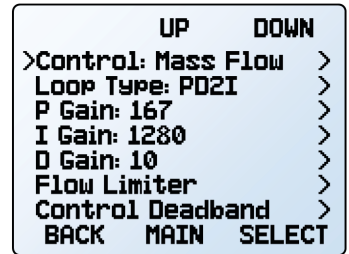

The control loop menu in PD²I control mode.

Troubleshooting Valve Performance with PID Tuning

The following issues can often be resolved by adjusting the PID gain values for your pressure controller.

Fast oscillation around the setpoint

- PD: Reduce the **P** gain in decrements of 10%.
- PD²I: Increase the **P** gain in increments of 10%, and then adjust the **I** gain to fine-tune.

Overshot setpoint

- PD: Reduce the **P** gain in decrements of 10%.
- PD²I: If **D** is not 0, increase the **P** gain in increments of 10%.

Delayed or unattained setpoint

- PD: Increase the **P** gain in increments of 10%, and then decrease the **D** gain by small amounts to fine-tune.
- PD²I: Increase the **P** gain in increments of 10%, and then increase the **I** gain to fine-tune.



Note: Valve tuning can be complex. Contact support if you need help (page 16).

Using a Control Deadband for Pressure Control

CONTROL → Control Loop → Control Deadband

The control deadband is designed to minimize the amount of gas exhausted and improve stability. There is no active control within the deadband setting.

To turn on the control deadband, enter a non-zero value in CONTROL → Control Deadband → Deadband. In order for the deadband to activate, the controller must reach the setpoint. If the process variable drifts to a deadband limit, active control resumes until the setpoint is reached again.

The controller can be set to either hold the current valve position or close the valve(s) in CONTROL → Control Loop → Control Deadband → When in Band. It is recommended to hold the current position on PC-Series controllers.

Example: With a setpoint of 30 PSIA, a deadband of ±0.25 PSIA allows absolute pressure to vary between 29.75 and 30.25 PSIA. The device will increase pressure until it reaches the setpoint of 30 PSIA. With a setting of **Hold valve position**, it will hold the current valve position until the pressure reading varies outside of the preset deadband.



Caution: PC-Series devices do not have an exhaust valve to reduce pressure when pressure exceeds the deadband. A dual-valve (PCD-Series) pressure controller with an exhaust valve is recommended for closed volumes.

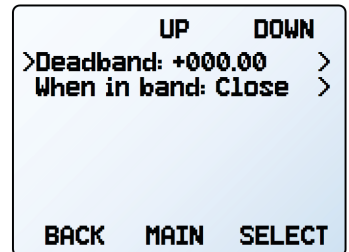

The deadband menu.

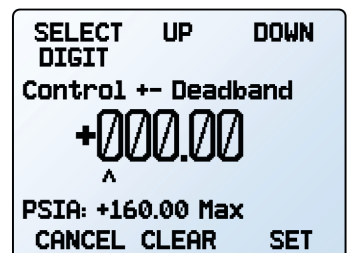

Choosing deadband size.

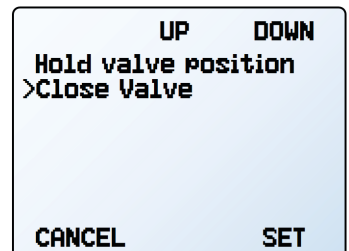

Choosing deadband options.

Setpoint Ramping

Setpoint ramping regulates how quickly the controller will reach the pressure setpoint. It is often used to prevent bursts of flow from damaging delicate instruments when starting a process.

To activate setpoint ramping, you will set a maximum ramp rate and configure when to enable the ramping function.

Setting the Ramp Rate

- **Ramp** is a quick way to change the maximum rate of change.
- **Units** is a quick way to change the engineering units used.
- **Set By Delta / Time** allows for more detailed control of the ramp rate including changing the value of the time period

Ramping Options

Changing ramping options allows you to have a ramp in only one direction, increasing or decreasing. It also allows you to ignore the ramp rate when initially powering on or commanding a zero setpoint.

- **Ramp Up** can toggle between on and off. When off, the ramp rate will not be honored when increasing pressure to reach a given setpoint.
- **Ramp Down** can toggle between on and off. When off, the ramp rate will not be honored when decreasing pressure to reach a given setpoint.
- **Power Up** toggles between **Allow Ramp** and **No Ramp**. If set to **No Ramp**, the device will ignore the ramp rate just after powering on, otherwise it will honor the ramp rate from a zero setpoint.
- **0 Setpt** determines whether the controller ramps when a zero setpoint has been given. If this setting is set to **No Ramp**, when given a zero setpoint, the controller will immediately snap to the zero setpoint; otherwise it will ramp at the selected rate.

Displaying Valve Drive Percentage

The valve drive is represented as a percentage of the amount of voltage driven to the valve. Percentages do not directly correlate with percentage open.

Viewing the valve drive percentage is particularly helpful for troubleshooting. An increased percentage over time likely indicates a clog in the system where more voltage is required to drive the valve to attain the same amount of flow. A valve percentage of 0% indicates the valve is closed.

This information may be displayed on the **main display** and/or as part of transmitted serial data. There are four valve display options:

- **None**: No valve information is displayed.
- **Main Screen**: Only on the **main display**.
- **Digital Data**: Only in the serial data frame.
- **Screen and Digital**: Both the **main display** and serial data frame.

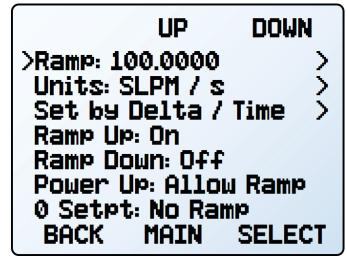

The setpoint ramping menu.

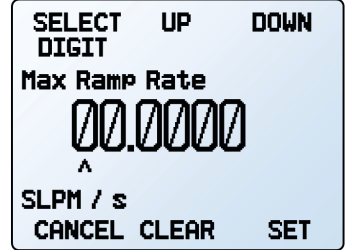

Setting a maximum ramp rate.

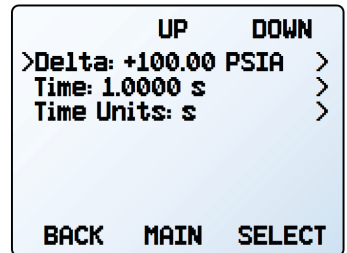

Configuring delta/time ramping.

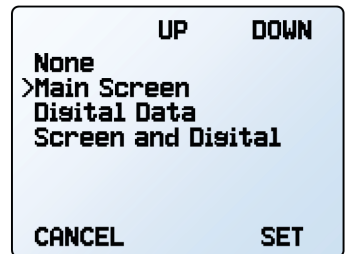

The valve display menu

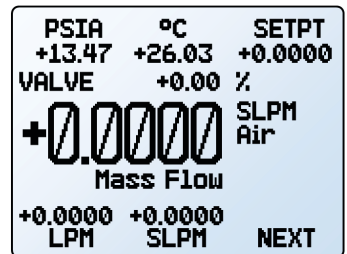

Valve percentage on the main display, above the large numbers.

Device Information

The **ABOUT** menu (**MENU** → **ABOUT**) contains useful information for setup, configuration, and troubleshooting.

Basic Device Information

ABOUT → **About Device**

This includes information on the following:

- **MODEL:** Device model
- **SERIAL NO:** Serial number
- **DATE MFG:** Manufacturing date
- **DATE CAL:** Most-recent calibration date
- **CAL BY:** Initials of the person who calibrated the device
- **SW:** Firmware version
- **Display SW** (color displays only): Firmware version of the display

Device Full Scale Ranges

ABOUT → **Full Scale Ranges**

This displays the maximum calibrated range of available pressure readings. Most will include only one type of pressure. Devices equipped with an optional barometer will show absolute, gauge, and barometric pressures.

Manufacturer Information

ABOUT → **About Manufacturer**

About Manufacturer usually includes:

- Manufacturer name
- Web address
- Phone number
- Email address

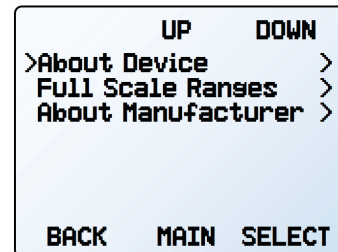

The about menu.

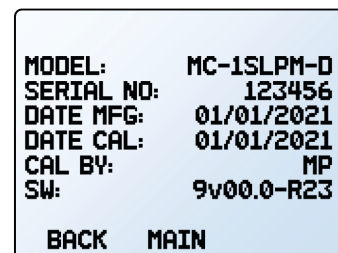

The about device screen.

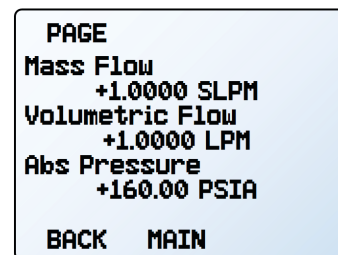

The full scale ranges screen.

Setup

Sensor Setup

MENU → SETUP → Sensor

Choosing Engineering Units

SETUP → Sensor → Engineering Units

Changing device engineering units alters both the display and the data frame. Choose the parameter whose unit you want to change, and then select your desired engineering unit, confirming the change on the last screen.

Pressure Averaging

SETUP → Sensor → Pressure Averaging

Averaging the pressure over a longer time may be useful in smoothing fluctuating readings. This menu changes the time constant of the geometric running average for pressure. Values roughly correspond to the time constant (in milliseconds) of the averaged values. Higher numbers generate a greater smoothing effect, to a maximum of 255 ms.

Zero Band

SETUP → Sensor → Zero Band

The zero band threshold is an amount of pressure under which pressure values are displayed as 0. The maximum zero band is 6.38%. For example, a 20 PSIG setting with a zero band value of 0.25% would display as 0 PSIG for all readings below 0.05 PSIG.

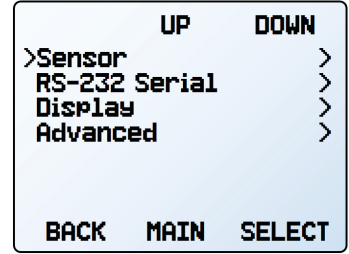

The setup menu.

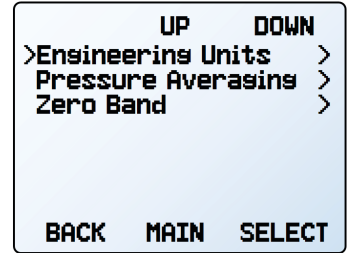

The sensor setup menu.

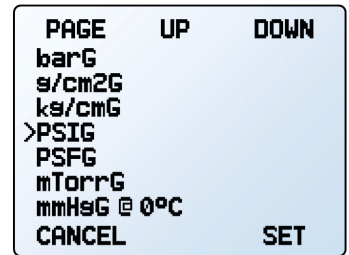

Selecting engineering units.

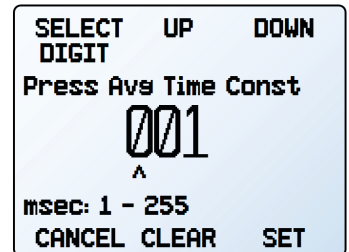

Selecting a pressure average.

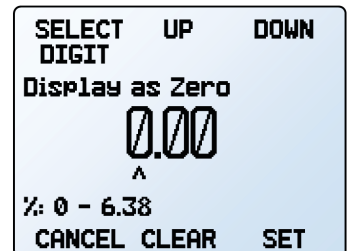

Selecting a zero band.

Configuring Serial Communications

MENU → SETUP → RS-232 Serial or RS-485 Serial

You can operate the pressure controller remotely via its data connection for easy streaming and logging of all data. Before connecting the pressure controller to a computer, ensure that it is ready to communicate with your computer by checking the options in this menu.

For more on how to issue commands from a computer, see [page 20](#).

Unit ID

SETUP → RS-232 Serial or RS-485 Serial → Unit ID

The unit ID is the identifier that a computer uses to distinguish your device from other, similar devices when connected to a network. Using the unit ID letters A–Z, you can connect up to 26 devices to a computer at the same time via a single COM port. This is called **polling mode** ([page 20](#)). Unit ID changes take effect when you select SET.

If you select “@” as the Unit ID, the pressure controller will enter **streaming mode** when you exit the menu ([page 21](#)).

Modbus RTU Configuration

SETUP → RS-232 Serial or RS-485 Serial → Modbus Address

SETUP → RS-232 Serial or RS-485 Serial → Modbus

Modbus Address

The Modbus address is the identifier that a computer or programmable logic computer (PLC) uses to distinguish your device from other devices when connected to a Modbus network. Values of 1–247 are available for use.

Managing Setpoint with an Idle Modbus Connection

If a Modbus connection is idle for a specified amount of time, the device can be configured to set a zero setpoint, or maintain the previous setpoint. The idle time will be infinite by default and can be set in seconds up to 99999.9 seconds (1 day, 3 hours, 46 minutes, 39.9 seconds).

Baud Rate

SETUP → RS-232 Serial or RS-485 Serial → Baud Rate

Baud rate is the speed at which digital devices transfer information. The pressure controller has a default baud rate of 19200 baud (bits per second). If your computer or software uses a different baud rate, you must change the pressure controller’s baud rate in the **BAUD** menu to ensure they match. Alternatively, you can change your computer’s baud rate in Windows® Device Manager. Baud rate changes take effect once you press SET, but you may need to restart the software for it to recognize the change.

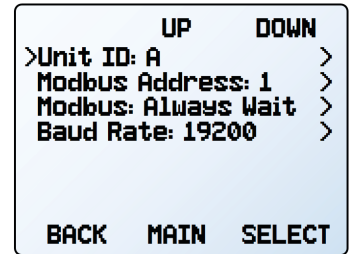

The serial communication menu.

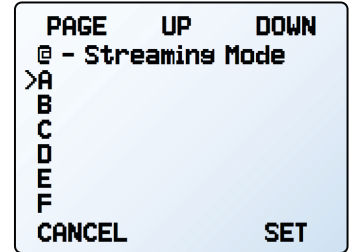

Choosing a unit ID, or streaming.

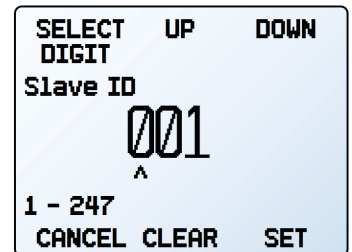

The Modbus address menu.

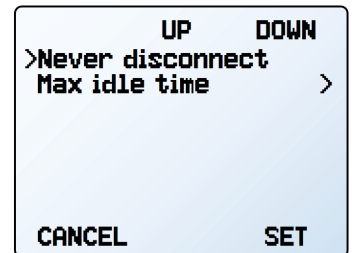

The Modbus idle menu.

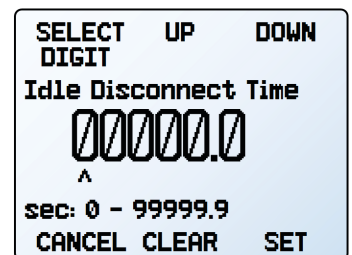

Setting a Modbus idle disconnect time.

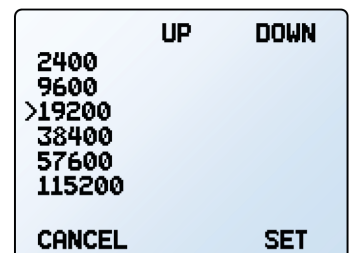

Baud rate options.

Display Setup

MENU → SETUP → Display

The options in the **display setup** menu adjust the contrast/brightness of the display and enable screen rotation.

Main Screen Options

SETUP → Display → MAIN Screen

- **Any Key Press** changes what happens when any of the parameter buttons on the **main display** (page 11) are pressed (pressure or temperature, for example). By default, these buttons highlight their measurement in the center of the display. If this option is set to **Show Actions Menu**, an option to change that parameter’s engineering units will be shown, as well as an option to highlight the parameter.
- **Show Valve Drive** shows or hides the valve’s drive percentage. See page 15.
- **Top Left Key Value** and **Bot Left Key Value** will show if the device has an optional barometer installed. This option configures which type of pressure (barometric, gauge, absolute) is displayed.

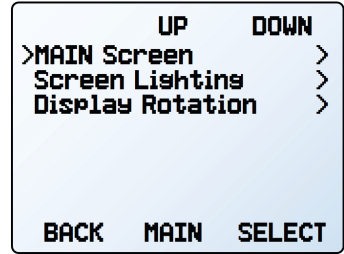

The display setup menu.

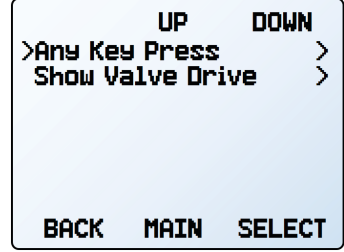

The options for pressing buttons on the main display.

Screen Lighting

SETUP → Display → Screen Lighting

The options and wording in the **screen lighting** menu will vary for monochrome versus color displays.

- On monochrome displays, press **LESS CONTRAST** or **MORE CONTRAST** to adjust the contrast levels and move the contrast indicator left or right. **POWER UP Lit** or **Dark** toggles whether the backlight of the unit will be on when the device powers on.
- On color displays, press **DIMMER** or **BRIGHTER** to adjust the brightness level and move the brightness indicator left or right.

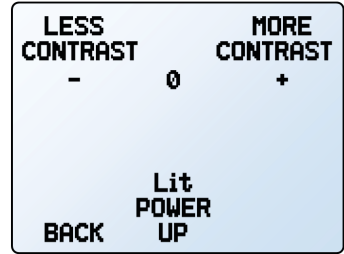

The monochrome contrast menu.

Display Rotation

SETUP → Display → Display Rotation

The device has the option of inverting (flipping) the screen upside-down, as configured in this menu.

Advanced Setup

MENU → SETUP → Advanced

The **advanced setup** menu contains settings and detailed information that are useful when troubleshooting with customer support.

Factory Restore

SETUP → Advanced → Factory Restore

This will immediately take you to a confirmation screen. When troubleshooting, an applications engineer may recommend doing a **Factory Restore**. If something is not acting as expected, please contact support (page 16) prior to doing a **Factory Restore**.

Register Status

SETUP → Advanced → Register Status

The **Register Status** screen displays live values for the internal device registers. Many of these values can help an applications engineer diagnose operational issues over the phone. Some register values clearly distinguish between hardware and operational problems, which speeds up the troubleshooting process.

Edit Register and Device Properties

SETUP → Advanced → Edit Register

SETUP → Advanced → Device Properties

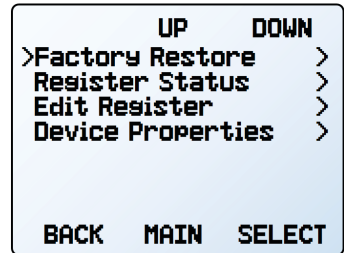

The advanced setup menu.

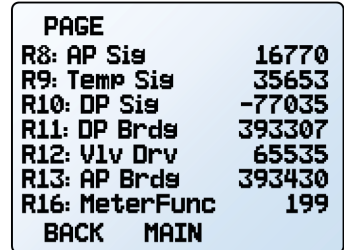

The register status list.



Warning: Editing these settings may cause the device to become inoperable. Do not modify them without working with an applications engineer.

Serial Communication

Connecting your device to a computer allows you to log the data that it generates. The pressure controller communicates digitally through its communications connector and cable using a real or virtual COM port on your computer. This section of the manual shows you how to operate the pressure controller using ASCII commands.

Modbus RTU Communication

For details on Modbus commands, contact support ([page 16](#)).

Establishing Communication

After connecting your pressure controller using a communications cable, you will need to establish serial communications through a real or virtual COM port on your computer or programmable logic computer (PLC).

- If the device is connected to a serial port, note its COM port number. This can be found in Windows® Device Manager.
- If you have used a USB cable to connect your device to your computer, then in most cases it will recognize your USB as a virtual COM port. If it does not, contact support ([page 16](#)).

The controller will be configured with the following settings:

- **Baud:** 19200 (by default; others can be used if the computer, its software and the controller are all set to the same rate)
- **Data bits:** 8
- **Parity:** none
- **Stop bits:** 1
- **Flow control:** none

Communication Programs

Although the device will communicate with any compatible terminal program over RS-232, PuTTY is a common option. A USB port or COM port will not supply enough power to your device to function. Please use another power source.

Configuring PuTTY

1. Download PuTTY from putty.org and run the installer.
2. Open PuTTY; it will start on the Configuration screen.
3. Click on the Terminal category. The changes we make here will cause PuTTY to act like a normal serial terminal, such that pressing enter will move the cursor to the next line and both what you type and what gets returned stay on the screen:
 - Check the box that says “Implicit LF in every CR.”
 - Select the “Force on” radio button in the “Local echo” section.
4. Click Connection, and then the Serial subcategory.
 - Set the Speed (baud) to 19200.
 - Set the Data bits to 8.
 - Set the Stop bits to 1
 - Ensure “None” is selected for both Parity and Flow control.
5. Click on the Session category.
 - Select the “Serial” radio button under “Connection type”.
 - Check that the COM port and baud rate (Speed) are correct.
6. Save your settings so they can be recalled again later.



Note: In the following examples,  indicates an ASCII carriage return (decimal 13, hexadecimal D). For many devices, this is the same as hitting the Enter key. Serial commands are not case-sensitive.

Polling Mode

Your controller is shipped in polling mode with a unit ID of **A**, unless requested otherwise. Each poll returns one line of data every time you request it. To poll, simply enter its unit ID.

Poll the device: `[unit ID]`

Example: `a` (polls unit A)

You can change the unit ID of a polling device by typing:

Change the unit ID: `[current unit ID]@[desired unit ID]`

Example: `a@=b` (changes unit A to unit B)

The front panel menu can also be used to change the unit ID ([page 18](#)). Valid IDs are letters A–Z, and up to 26 devices may be connected at a time, as long as each unit ID is unique.

Streaming Mode

In streaming mode, your device automatically sends a line of live data at regular intervals. Only one unit on a COM port may be in streaming mode at a time.

To put your pressure controller into streaming mode, type:

Begin streaming: `[unit ID]@=@`

Example: `A@=@` (Begins streaming unit A)

This is equivalent to changing the unit ID to “@”. To take the device out of streaming mode, assign it a unit ID by typing:

Stop streaming: `@@[desired unit ID]`

Example: `@@=a` (stops and assigns unit ID of A)

When sending a command in streaming mode, the flow of data will not stop while the user is typing. This may make the commands you type unreadable. If the device does not receive a valid command, the command will be ignored. If in doubt, simply hit `↵` and start again.



Note: The default streaming interval is 50 ms, but can be modified by editing Register 91 while the device is in polling mode:

Set streaming interval: `[unit ID]w91=[time in milliseconds]`

Example: `aw91=500` (streams data every 500 ms)

Taring

Taring pressure ensures that the gauge or differential pressure sensor reads zero. Taring an absolute pressure sensor requires a barometer and aligns the absolute pressure sensor with the external barometric pressure. For an accurate tare, a gauge or absolute pressure sensor must be open to atmosphere, while both ports of a differential sensor must be connected to the same pressure source (which may be atmosphere).

To tare a gauge or differential pressure device:

Tare gauge pressure: `[unit ID]p`

Example: `ap`

To tare an absolute pressure device

Tare absolute pressure: `[unit ID]pc`

Example: `apc`

Absolute pressure devices will return a ? if the device is not configured with an internal barometer.

Collecting Data

Collect live data by typing the `[unit ID]` command or by setting your pressure controller to streaming. Each line of data for live measurements appears in the format below, but the unit ID is not present in streaming mode.

Example:

A	+20.00	+20.00
ID	Gauge Pressure	Setpoint

Single spaces separate each parameter, and each value is displayed in the chosen device engineering units ([page 17](#)). You can query the engineering units of the serial data frame by typing:

Query live data info: `[unit ID]??d*`

Example: `a??d*` (returns the data frame descriptions)

Additional columns, including status codes ([page 6](#)), may be present after the last number. The unit ID ([page 18](#)) appears in the data frame only when the device is in polling mode.

Commanding a New Setpoint

Before attempting to send a setpoint to your controller serially, confirm that its setpoint source is set to **Serial/Front Panel** (page 12). There are two ways to command a new setpoint over a serial connection, as described below. In either of these methods, the data frame returns the new setpoint value when it has been accepted as a valid setpoint.

Sending Setpoints as Floating Point Numbers

This is how to send the desired setpoint value as a floating point number in the selected engineering units:

New setpoint: [unit ID]s[floating point number setpoint]↵

Example: as5.44↵ (setpoint of +5.44 PSIG)

When using a pressure controller configured to control negative pressure, negative setpoints are sent by adding a hyphen for the minus sign (-):

New setpoint: [unit ID]s[floating point number setpoint]↵

Example: as-15.00↵ (setpoint of -15.00 PSIG)

Quick Command Guide

Serial commands are not case-sensitive. In these examples, the unit ID of the controller is **a**. If you require more advanced serial communication commands, please contact support (page 16).

Change unit ID: [current unit ID]@[desired unit ID]↵
Tare PSIG or PSID: ap↵
Tare absolute pressure: apc↵ (requires optional barometer)
Poll the live data frame: a↵
Begin streaming data: a@=@↵
Stop streaming data: @@=[desired unit ID]↵
Set streaming interval: aw91=[number of milliseconds]↵
New setpoint: as[setpoint as floating point #]↵
New setpoint: a[setpoint as integer where 64000 is full scale]↵
Hold valve(s) at current position: ahp↵
Hold valve(s) closed: ahc↵
Cancel valve hold: ac↵
Query live data info: a??d*↵
Manufacturer info: a??m*↵
Firmware version: a??m9↵
Lock the front display: al↵
Unlock front display: au↵

Troubleshooting

If you run into trouble with your device's installation or operation, please get in touch with support ([page 16](#)).

General Use

Issue: *My device does not turn on or has trouble staying on.*

Action: Check power and ground connections. Please reference the technical specifications to assure you have the proper power for your model.

Issue: *The buttons do not work, and the screen shows LCK.*

Action: The device buttons were locked out via a serial command. Press and hold all four outer buttons to unlock the interface.

Issue: *I can't read the display easily.*

Action: During the day, increasing contrast or brightness will help the display's visibility ([page 19](#)). For monochrome displays under low-light conditions, push the bottom button located below the display to turn on the backlight ([page 19](#)).

Issue: *The analog output signal indicates values lower than what appears on my instrument's display.*

Action: Analog signal voltage degrades over long distances. You can minimize this effect by using wires with a heavier gauge, especially in the ground wire.

Issue: *How often do I need to calibrate my device?*

Action: Annual recalibrations are recommended. Check your device's last calibration date by selecting **MENU** → **ABOUT** → **About Device**. If it is time to recalibrate, get in touch with support ([page 16](#)).

Issue: *I dropped my device. Is it OK? Do I need to recalibrate?*

Action: If it turns on and appears to respond normally, then it is probably OK. It may or may not need a recalibration. Give it a tare, and compare it against a pressure standard you know is accurate. If it checks out, keep using it, but tell your calibrator about the drop at your next annual recalibration.

Issue: *How can I see pressure in different units?*

Action: From the main menu, select **SETUP** → **Sensor** → **Engineering Units**. For more information, see [page 17](#).

Pressure Readings

Issue: *My controller won't reach its setpoint.*

Action: You must ensure that there is enough supply pressure to reach the setpoint. If increasing the pressure doesn't help, check to see if there is a clog. Teflon tape can get stuck in the flow channel and block flow. Make sure to clean out any loose Teflon tape and never tape the first two threads entering the device to help avoid this issue

Issue: *My pressure readings are negative.*

Action: If a negative reading is not expected, your device may need to be tared ([page 11](#)). Ensure pressure is at zero, and tare it.

Issue: *My pressure readings jump to zero when pressures are low.*

Action: Your device is equipped with a programmable zero band that is preset at the factory. Reduce your deadband threshold by selecting **SETUP** → **Sensor** → **Zero Band**.

Issue: *Does the controller work if it is laying down? Will it be accurate?*

Action: Yes to both for small valve controllers! The pressure controller is internally compensated for many situations, so you can use it sideways, on its back, or upside-down. For upside-down installations, you may want to rotate the display 180° ([page 19](#)). However, they should be tared again after changing their orientation. Large-valve controllers (PCR- and PCR3-Series) should be operated with the valve cylinder vertical and upright.

Issue: *Can I attach the controller to a vibrating device? Will it be accurate?*

Action: Yes, and yes! The pressure controller is internally compensated for any changes in orientation, including rapid vibrations. Noise will increase if the pressure controller is vibrating. Large-valve controllers are not recommended for use on vibrating surfaces.

Issue: *My pressure controller disagrees with another device I have in line.*

Action: Pressure devices can normally be compared against one another provided there are no leaks between the two devices. Another possibility is an improper tare error ([page 11](#)).

Issue: *Can I use the controller with other gases or liquids?*

Action: Yes for gases, maybe for liquids. Your pressure controller is designed to operate independent of the media being used. One thing to check before changing gases or liquids is the chemical and material compatibility of the gas being used with the wetted materials inside the controller. We also recommend contacting support ([page 16](#)) before switching over to liquid pressure control.

Serial Communications

Issue: *I can't communicate to the device when it is connected to my PC.*

Action:

1. Make sure the baud rate your software and COM port required is the one your pressure controller is using (**MENU → SETUP → RS-232 Serial or RS-485 Serial → Baud Rate**).
2. Check the unit ID (**MENU → SETUP → RS-232 Serial or RS-485 Serial → Unit ID**) to make sure you are addressing it properly with your serial commands.
3. Check the pinout (common pinouts are listed starting on [page 26](#)).
4. Make sure the COM number matches the one your software is using to connect to the pressure controller.
5. On the external serial communications device (computer, PLC, etc.), be sure that the pressure control (handshaking) settings are set as on [page 20](#).

Still experiencing issues? Please contact support. See “Contact Information” on [page 16](#).

Maintenance

Cleaning

This device requires minimal maintenance. If necessary, the outside of the device can be cleaned with a soft dry cloth. Avoid excess moisture or solvents.

The primary causes of damage and/or long-term inaccuracy in these devices are contamination and/or corrosion damage. Fluid should be filtered for particulates or biological materials that may grow in the device.

Recalibration

The recommended period for recalibration is once every year. A label located on the back of the device lists the most recent calibration date. This date is also stored inside your device and is visible by selecting **MENU → ABOUT → About Device**.

When it is time for your device's annual recalibration, contact support ([page 16](#)) with your device's serial number and your contact information.

Reference Information

Engineering Units

Pressure Units

Absolute or Barometric	Gauge	Differential	Notes
PaA	PaG	PaD	Pascal
hPaA	hPaG	hPaD	Hectopascal
kPaA	kPaG	kPaD	Kilopascal
MPaA	MPaG	MPaD	Megapascal
mbarA	mbarG	mbarD	Millibar
barA	barG	barD	Bar
g/cm ² A	g/cm ² G	g/cm ² D	Gram force per square centimeter [†]
kg/cm ² A	kg/cm ² G	kg/cm ² D	Kilogram force per square centimeter*
PSIA	PSIG	PSID	Pound force per square inch
PSFA	PSFG	PSFD	Pound force per square foot
mTorrA	mTorrG	mTorrD	Millitorr
torrA	torrG	torrD	Torr
mmHgA	mmHgG	mmHgD	Millimeter of mercury at 0°C
inHgA	inHgG	inHgD	Inch of mercury at 0°C
mmH ₂ OA	mmH ₂ OG	mmH ₂ OD	Millimeter of water at 4°C (NIST conventional) [†]
mmH ₂ OA	mmH ₂ OG	mmH ₂ OD	Millimeter of water at 60°C [†]
cmH ₂ OA	cmH ₂ OG	cmH ₂ OD	Centimeter of water at 4°C (NIST conventional) [†]
cmH ₂ OA	cmH ₂ OG	cmH ₂ OD	Centimeter of water at 60°C [†]
inH ₂ OA	inH ₂ OG	inH ₂ OD	Inch of water at 4°C (NIST conventional) [†]
inH ₂ OA	inH ₂ OG	inH ₂ OD	Inch of water at 60°C [†]
atm			Atmosphere
m asl			Meter above sea level
ft asl			Foot above sea level
V			Volt
count	count	count	Setpoint count, 0–64000
%	%	%	Percent of full scale

Time Units

Label	Notes
ms	Milliseconds
s	Seconds
m	Minutes
hour	Hours
day	Days

* Displayed as kg/cmA, kg/cmG, or kg/cmD.

[†] Superscript and subscript numerals are displayed as lining (normal) numerals.

Pinouts

Check the calibration data sheet and pinout for your device.

See [page 20](#) for additional important information about connecting your device to a computer for serial commands.

8-Pin Mini-DIN (Default)

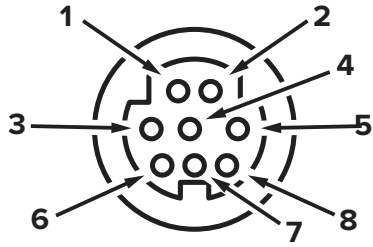

Female Connector: Device

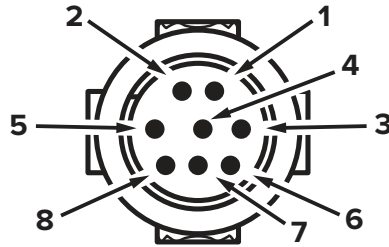

Male Connector: Cable

Pin	Function
1	Not Connected <i>Optional: 4–20 mA primary output signal</i>
2	Static 5.12 Vdc <i>Optional: secondary analog output (4–20 mA, 0–5 Vdc, 1–5 Vdc, 0–10 Vdc) or basic alarm</i>
3	Serial RS-232RX Input Signal <i>Optional: RS-485 A</i>
4	Analog Setpoint Input
5	Serial RS-232TX Output Signal <i>Optional: RS-485 B</i>
6	0–5 Vdc Analog Out <i>Optional: 1–5 Vdc or 0–10 Vdc output signal</i>
7	Power In
8	Ground (common for power, digital communications, analog signals, and alarms)



Caution: Do not connect power to pins 1 through 6, as permanent damage can occur. It is common to mistake pin 2 (labeled 5.12 Vdc Output) as the standard 0–5 Vdc analog output signal. Pin 2 is normally a constant 5.12 Vdc.

Locking Industrial Connector Pinout

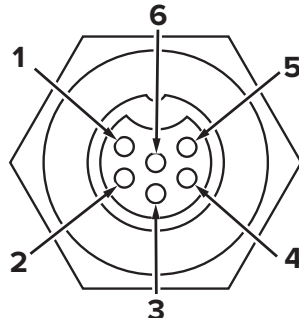
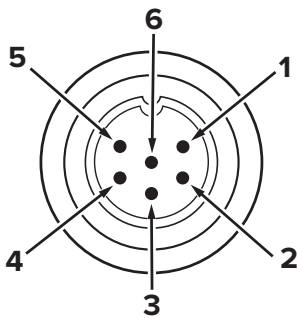

Pin	Function
1	Power In (+)
2	RS-232TX / RS-485 B
3	RS-232RX / RS-485 A
4	Analog Setpoint Input
5	Ground (common for power, communications, and signals)
6	Analog Out (voltage or current as ordered)



Note: The availability of different output signals depend on the options ordered.

9-Pin D-Sub Connector Pinouts

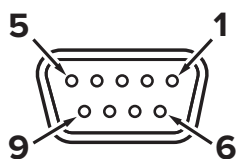

Female Connector

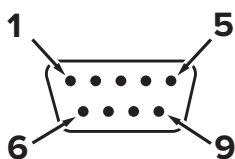

Male Connector

Pin	DB9 (Female) DB9M (Male)	DB9A / DB9K	DB9R	DB9T	DB9U	DB9G	DB9H	DB9I	DB9N
1	Current Out	NC	TX or B	TX or B	RX or A	RX or A	TX or B	NC	Power In
2	Analog Out 2	Analog Out	Analog Out	Analog Out	Analog Out	Analog Out	Analog Out	Analog Out	Analog In
3	RX or A	Power In	Analog In	Power In	Power In	Ground	Analog In	Power In	Analog Out
4	Analog In	Ground	Ground	Ground	Ground	Power In	RX or A	Ground	NC
5	TX or B	TX or B	NC	NC	NC	Ground	Analog Out 2	NC	Ground
6	Analog Out	Analog In	RX or A	Analog In	Analog In	TX or B	NC	Analog In	Ground
7	Power In	Ground	Power In	Ground	Ground	Analog In	Power In	Ground	RX or A
8	Ground	Ground	Ground	Ground	Ground	Current Out	Ground	RX or A	TX or B
9	Ground	RX or A	Ground	RX or A	TX or B	Ground	Ground	TX or B	NC5

15-Pin D-Sub Connector Pinouts

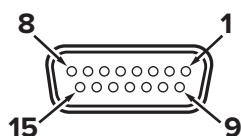

Female Connector: Cable

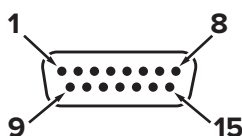

Male Connector: Device

Pin	DB15	DB15A	DB15B	DB15H	DB15K	DB15O	DB15S
1	Ground	Ground	Ground	NC	NC	Ground	Ground
2	Analog Out	Analog Out	Analog Out	RX or A	Analog Out	NC	Analog Out
3	Ground	Analog In	NC	NC	NC	NC	NC
4	NC	Ground	NC	NC	NC	Analog Out	NC
5	Power In	Ground	Power In	Ground	Ground	Power In	Ground
6	NC	Ground	NC	Analog Out	NC	NC	NC
7	NC	Power In	NC	Ground	Power In	Analog In	NC
8	Analog In	TX or B	Analog In	NC	Analog In	NC5	Analog In
9	Ground	Ground	Ground	NC	Analog Out 2	Ground	Ground
10	Ground	NC	Ground	Analog Out 2	NC	Ground	Ground
11	Analog Out 2	NC	Analog Out 2	Power In	Ground	Analog Out 2	Analog Out 2
12	NC	Analog Out 2	NC	Ground	Ground	NC	RX or A
13	RX or A	NC	NC	NC	RX or A	NC	Power In
14	Ground	NC	RX or A	Analog In	TX or B	RX or A	TX or B
15	TX or B	RX or A	TX or B	TX or B	Ground	TX or B	Ground

Key of Terms:

Analog In
Analog Setpoint Input

Analog Out
0–5 Vdc output signal (1–5,
0–10 Vdc optional)

Analog Out 2
5.12 Vdc or optional secondary
analog output

Current Out
Not connected

NC Not connected

Power In (+Vdc)

RX or A
Serial RS-232RX or RS-485 A

TX or B

Serial RS-232TX or RS-485 B

Ground

Common for power, digital
communications, analog signals, alarms

M12 Connector Pinouts

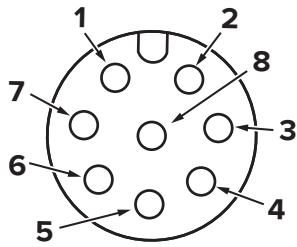

Female Connector: Cable

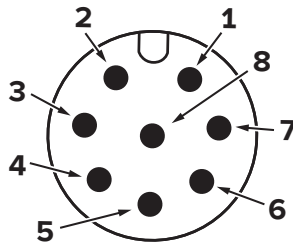

Male Connector: Device

Pin	M12	M12MD
1	0–5 Vdc Output Signal <i>Optional: 1–5 or 0–10 Vdc</i>	Not Connected <i>Optional: 4–20 mA primary output signal</i>
2	Power In	Static 5.12 Vdc <i>Optional: Secondary analog output (4–20 mA, 0–5 Vdc, 1–5 Vdc, 0–10 Vdc) or basic alarm</i>
3	Serial RS-232 RX signal <i>Optional: RS-485 A</i>	Serial RS-232 RX Signal <i>Optional: RS-485 A</i>
4	Analog Setpoint Input	Analog Setpoint Input
5	Serial RS-232 TX signal <i>Optional: RS-485 B</i>	Serial RS-232 TX Signal <i>Optional: RS-485 B</i>
6	Static 5.12 Vdc <i>Optional: Secondary analog output (4–20 mA, 0–5 Vdc, 1–5 Vdc, 0–10 Vdc) or basic alarm</i>	0–5 Vdc Output Signal <i>Optional: 1–5 or 0–10 Vdc</i>
7	Ground (common for power, digital communications, analog signals, and alarms)	Power in
8	Inactive <i>Optional: 4–20 mA primary output signal</i>	Ground (common for power, digital communications, analog signals, and alarms)