

SENSOR PERFORMANCE	
Mass Flow Accuracy at calibration conditions ¹	±0.8% of reading and ±0.2% of full scale
High Accuracy Option ¹	±0.4% of reading and ±0.2% of full scale Available for ranges ≥5 SCCM and ≤500 SLPM
Bidirectional Option ¹	±0.2% of full scale in addition to base accuracy (above)
Repeatability	±0.2% of full scale
Flow Measurement Range	1–100% of full scale
Temperature Sensitivity	Mass flow zero shift and span shift: 0.02% of full scale per °C from 25°C
Pressure Sensitivity	Mass flow zero shift and span shift: ±(0.08% of reading + 0.02% of full scale) per atmosphere from calibration conditions
Operating Temperature Range	–10–60°C (expanded range available)
Temperature Accuracy	±0.75°C
Operating Pressure Full Scale	160 PSIA (additional options available)
Pressure Accuracy	±0.5% of full scale
Totalizer Volume Uncertainty	±0.5% of reading additional uncertainty
Sensor Response Time	<1 ms
Typical Indication Response Time ²	0.5 SCCM–5 SCCM: 100–4000 ms 10 SCCM–20 SLPM: <10 ms 50 SLPM–5000 SLPM: 65–255 ms
Typical Warm-Up Time	<1 s

¹ Stated accuracy is after tare under equilibrium conditions, includes repeatability and linearity.

² Indication response time includes user adjustable averaging up to 255 ms.

MECHANICAL	
Minimum Operating Pressure	11.5 PSIA common mode pressure (lower operating pressures available) Differential pressure must exceed model pressure drop, see below for details
Maximum Operating Pressure	Damage possible above 175 PSIA common mode pressure Damage possible above 75 PSI differential pressure
Ingress Protection	IP40 (consult Alicat for weatherproofing options)
Humidity Range	0–100%, non-condensing
Wetted Materials	316L stainless steel, FFKM standard, FKM or EPDM as needed for some gases.

COMMUNICATIONS	
Analog I/O Options ³	4–20 mA, 0–5 VDC, 1–5 VDC, 0–10 VDC
Analog Signal Accuracy ³	±0.1% of full scale additional uncertainty
Digital I/O Options	RS-232 Serial by default RS-485 Serial, Modbus RTU (over RS-232 or RS-485), Modbus TCP/IP, DeviceNet, EtherCAT, EtherNet/IP, Profibus Portable devices (MBS models): Serial over Micro-USB
Electrical Connection Options	6 pin locking, 8 pin mini-DIN, 8 pin M12, DB-9, DB-15 (contact Alicat for custom pinouts) Portable devices (MBS models): Power over Micro-USB Type B
Power Requirements ⁴	9–24 VDC, 40 mA (12–24 VDC, 80 mA if equipped with 4–20 mA or 0–10 VDC output) Portable devices (MBS models): 5 VDC, 1 A recommended via an outlet adapter to USB. Battery life for monochrome screens is 14–18 hours (backlight dependent), or 8 hours for TFT screens
Battery Life (MBS Series)	Monochrome screen: 18 hours, user configurable, contrast dependent Color TFT screen: 8 hours, user configurable, contrast dependent
Digital Data Update Rate ⁴	40 Hz at 19200 baud
Analog Data Update Rate ⁴	1 kHz
Display Update Rate	10 Hz

³ Analog outputs unavailable on portable devices.

⁴ Consult the individual operating bulletins for specific industrial protocol power requirements and data transmission specifications.

FEATURES	
STP Reference Conditions	25°C and 1 atm (default), user configurable
NTP Reference Conditions	0°C and 1 atm (default), user configurable
Monochrome LCD or Color TFT Display with integrated touchpad	Simultaneously displays mass flow, volumetric flow, temperature, and pressure
Gas Select™	130 user selectable gases stored internally. Each gas optimized to match NIST's REFPROP 10 gas property calculations across the operating temperature and pressure ranges for highest accuracy.
COMPOSER™	20 user definable gas mixes. Each mix may have up to 5 gases with 0.01% precision.

RANGE-SPECIFIC TECHNICAL DATA			
Full scale flow	Pressure drop at full scale flow venting to atmosphere	Process connections ⁵	Mount tap size
0.5–50 SCCM	1.0 PSID	M5 female thread (10-32 compatible) ⁶	2× 8-32 UNC 0.175 in [4.45 mm]
100 SCCM–20 SLPM	1.0 PSID	1/8" NPT female	2× 8-32 UNC 0.350 in [8.89 mm]

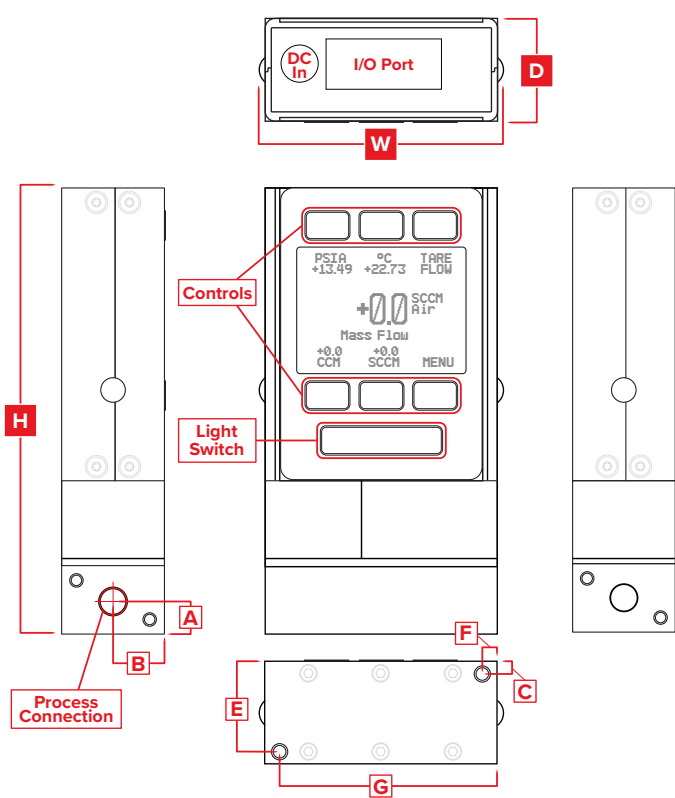

DIMENSIONS ⁷										WEIGHT ⁷
Full scale flow	Height	Width	Depth	A	B	C	E	F	G	
0.5–50 sccm	4.397 in	2.375 in	1.050 in	0.336 in	0.525 in	0.125 in	0.925 in	0.150 in	2.225 in	≈ 0.8 lb
	111.68 mm	60.33 mm	26.67 mm	8.53 mm	13.34 mm	3.18 mm	23.50 mm	3.81 mm	56.52 mm	≈ 0.4 kg
100 SCCM–20 SLPM	4.567 in	2.375 in	1.050 in	0.350 in	0.525 in	0.125 in	0.925 in	0.150 in	2.225 in	≈ 1.0 lb
	116.00 mm	60.33 mm	26.67 mm	8.89 mm	13.34 mm	3.18 mm	23.50 mm	3.81 mm	56.52 mm	≈ 0.5 kg

⁷ Portable devices (MBS Series) add 1.646" [41.81 mm] to height, and 0.2 lb. [90.72 g] to weight.

RANGE-SPECIFIC TECHNICAL DATA

Full scale flow	Pressure drop at full scale flow venting to atmosphere	Process connections ⁵	Mount tap size
50 SLPM	2.0 PSID	¼" NPT female	4× 8-32 UNC 0.375 in [9.53 mm]
100 SLPM	2.5 PSID	¼" NPT female	4× 8-32 UNC 0.375 in [9.53 mm]
250 SLPM	2.1 PSID	½" NPT female	4× 8-32 UNC 0.375 in [9.53 mm]
500 SLPM	4.0 PSID	¾" NPT female	4× 8-32 UNC 0.375 in [9.53 mm]
1000 SLPM	6.0 PSID	¾" NPT female	4× 8-32 UNC 0.375 in [9.53 mm]
2000 SLPM	5.0 PSID	¾" NPT female	4× 8-32 UNC 0.330 in [8.38 mm]
3000 SLPM	7.1 PSID	1½" NPT female	4× 8-32 UNC 0.330 in [8.38 mm]
5000 SLPM	3.4 PSID	1½" NPT female	4× 8-32 UNC 0.330 in [8.38 mm]

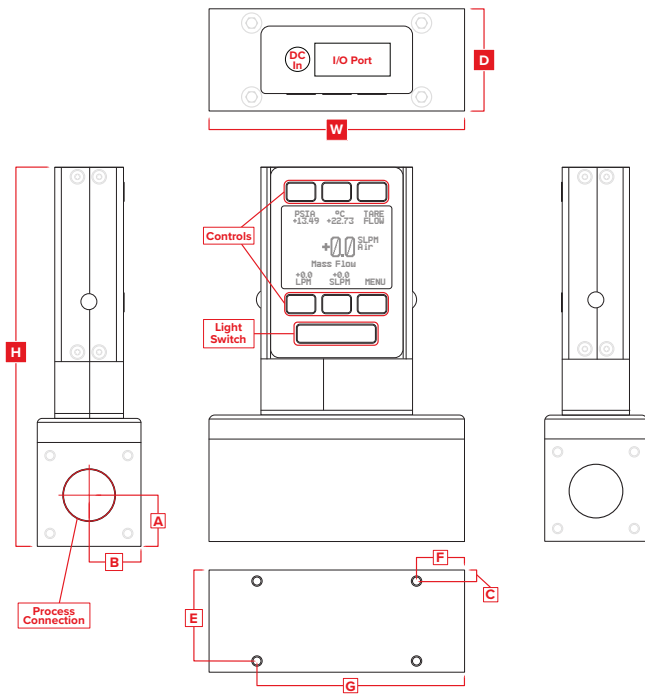

Representative Examples

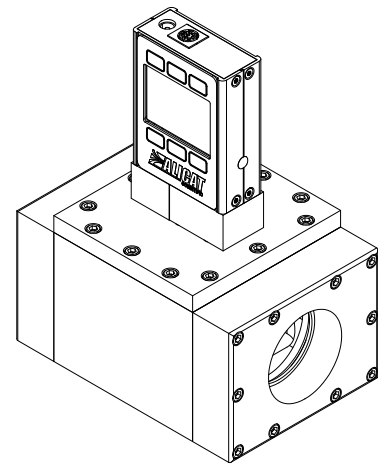
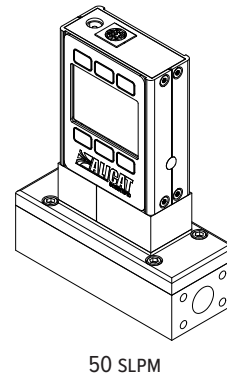

DIMENSIONS⁷

Full scale flow	Height	Width	Depth	A	B	C	E	F	G	WEIGHT ⁷
50–100 SLPM	5.067 in	4.000 in	1.600 in	0.500 in	0.800 in	0.175 in	1.425 in	0.750 in	3.250 in	≈ 2.4 lb
	128.70 mm	101.60 mm	40.64 mm	12.70 mm	20.32 mm	4.45 mm	36.20 mm	19.05 mm	82.55 mm	≈ 1.1 kg
250 SLPM	5.667 in	4.000 in	1.600 in	0.800 in	0.800 in	0.175 in	1.425 in	0.750 in	3.250 in	≈ 3.5 lb
	143.94 mm	101.60 mm	40.64 mm	20.32 mm	20.32 mm	4.45 mm	36.20 mm	19.05 mm	82.55 mm	≈ 1.6 kg
500–1000 SLPM	5.667 in	4.000 in	1.600 in	0.800 in	0.800 in	0.175 in	1.425 in	0.750 in	3.250 in	≈ 3.5 lb
	143.94 mm	101.60 mm	40.64 mm	20.32 mm	20.32 mm	4.45 mm	36.20 mm	19.05 mm	82.55 mm	≈ 1.6 kg
2000–3000 SLPM	5.987 in	5.200 in	2.900 in	1.120 in	1.450 in	0.200 in	2.700 in	1.350 in	3.850 in	≈ 4.5 lb
	152.07 mm	132.08 mm	73.66 mm	28.45 mm	36.83 mm	5.08 mm	68.58 mm	34.29 mm	97.79 mm	≈ 2.0 kg
5000 SLPM	7.083 in	5.600 in	3.840 in	1.450 in	1.920 in	0.295 in	3.545 in	1.550 in	4.050 in	≈ 14.0 lb
	179.91 mm	142.24 mm	97.54 mm	36.83 mm	48.77 mm	7.49 mm	90.04 mm	39.37 mm	102.87 mm	≈ 6.4 kg

⁷ Portable devices (MBS Series) add 1.646" [41.81 mm] to height, and 0.2 lb. [90.72 g] to weight.